

REQUEST FOR PROPOSAL

**SUPPLY and INSTALLATION of EQUIPMENT
for WIDE-BEAM SUN SIMULATOR FACILITY**

Version: 0

**Star Sensor System Group
Laboratory for Electro-Optics Systems
PEENYA, BANGALORE-58**

1. INTRODUCTION

This request for proposal (RFP) is for supplying, installing and commissioning of “**Equipment for Wide-beam Sun Simulator Facility**”. The enclosed document provides necessary specifications / requirements to be met by the vendors for the development, delivery and the installation of the equipment. It also provides the acceptance tests, deliverables, schedules and warranty details.

The proposal submitted in response to this RFP should be in conformity with the requirements / specifications laid down in this document. This document is organized with following chapters: (2) Scope of the work, (3) Technical specification, (4) Acceptance test plan, (5) Warranty, (6) Installation and Training, (7) deliverables and schedules, (8) Packaging and shipping, (9) Previous experience

2. SCOPE OF THE WORK:

The scope of work for the vendor is highlighted in this list:

- Supply of items as per section 3
- Installation and commissioning of the supplied items
- Acceptance test at LEOS as per section 4
- Training of functional operation of applicable items

3. TECHNICAL SPECIFICATIONS:

The facility is required to simulate wide Sun-light beam from one direction in a clean dark background room facility. A DUT (Design Under Test) will be mounted on a motion controlled mechanical stand, that will rotate in one-axis to create different angles between Sun-beam and look direction of the DUT. LEOS will provide two rooms: (1) clean room and (2) source room. Clean room will be kept in dark and connected to source room via a view port. View port will pass beam of Sun simulator light falling on the DUT.

3.1. General System Description

- 3.1.1. The DUT (Design Under Test) in the facility is an optical system.
- 3.1.2. The list of equipment shall be supplied by the vendor: (a) Sun simulator, (b) View-port glass, (c) Stand for DUT with 4-dof motion control, (d) Light absorbing Sticker for room wall and (e) reference solar cell with digital meter
- 3.1.3. A representative block diagram of the facility with dimension is shown in figure-1. The vendor shall provide a technical sketch highlighting each element fitting to the

dimension of the room.

- 3.1.4. The vendor shall highlight list of items required from LEOS for successful installation.
- 3.1.5. Grounding scheme shall be provided by the vendor to protect the simulator and ensure safety for the working personnel.
- 3.1.6. The vendor shall deliver and install all the above equipment and accessories at LEOS premises. The facility shall compliance to the list acceptance test as per section 4 after installation.
- 3.1.7. The equipment shall be reliable, high performance, simple in operation and shall conform to all safety regulations as applicable. Following sections elaborate technical specification of the above equipment.

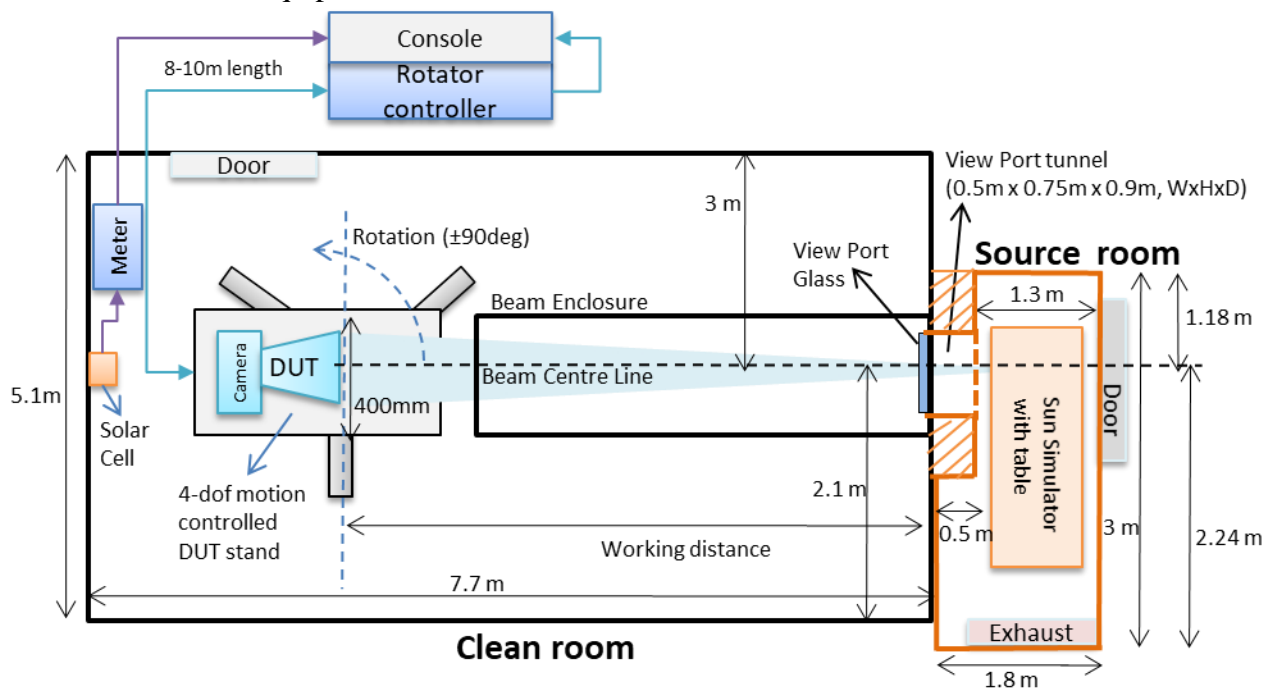

Fig-1: Representative Block diagram of the Facility with equipment

3.2. Sun Simulator:

Sun Simulator is required to simulate wide-beam of Sun-light equivalent to Sun’s irradiance and spectrum at the entry point of DUT. The light source of sun simulator shall fit in source room (fig-1) and if any optical element of the simulator requires to be kept inside clean room, it may be planned. Following specifications for the Sun simulator are to be met:

Table-1: Specification of Sun simulator

Sr. No.	Specification / description	Specification value
1	Irradiance at DUT end	0.2 ± 0.05 Solar Constant
2	Emitting Spectrum	350 nm – 1700 nm (ozone free source)
3	Spectral match	AM0, Class A ($< \pm 25\%$ from 400-1100nm)
4	Illuminated area at DUT end	$400^{\pm 10} \times 400^{\pm 10}$ mm OR dia. $400^{\pm 10}$ mm
5	Beam divergence (typical)	$< \pm 1^\circ$ (if it is higher value, beam enclosure should block it from illuminating the room)
6	Working distance (Viewport wall to DUT)	$5.5^{\pm 0.5}$ m
7	Spatial non-uniformity of irradiance at DUT end	$< 10\%$
8	Temporal instability of irradiance	Short term (1 hour): $< \pm 2\%$ Long term (24 hours): $< \pm 5\%$
9	Light source Lifetime	≥ 1000 hours
10	Cooling system for source	(a) Forced Air-cooling (Typical) (b) Automatic stop of lamp operation on cooling system failure
11	Control Panel Display	Electrically controlled front panel with intensity meter, lamp current meter, lamp voltage meter, lamp ON/OFF, elapsed time meter, etc. If any additional features are essential for operation, the vendor may include.
12	Safety features	(a) The design of the simulator shall confirm to ASTM/IEC or equivalent international standards and shall confirm to all safety regulations applicable. (b) The power supply to the simulator shall have all necessary control units including current limiting with all operational switches and displays.
13	Personal Protective Equipment	Safety clothing, gloves, face shield, safety goggles necessary for safety of the personnel involved in maintenance and servicing of solar simulation system. Qty: 1 set
14	Power Input	$415V \pm 10\%$, 3ph, $50Hz \pm 3\%$; OR $230V \pm 10\%$, Single phase, $50 Hz \pm 3\%$.
15	Power Consumption	Shall specify load and phase requirements
16	Beam-line Direction	The solar beam shall be in line to the horizontal axis passing through center of the view-port.
17	Beam-center height from floor	$1.44^{\pm 0.05}$ m (in clean room) and $1.41^{\pm 0.05}$ m (in source room)

18	Table support	Shall be provided as per sun simulator requirement, fitting within the room (refer fig-1). If any part of the simulator is required to be inside clean room, the vendor shall provide table stand for it with blackened, mat finish.
19	Compatibility with available room dimension	Light source for Sun simulator should fit within source room dimension and emits light beam via view port to the clean room (as shown in fig-1). If any front lens of simulator requires to be inside clean room, it is acceptable.
20	Beam Enclosure	The beam path from View port/ Exit port to the DUT should be covered by a black enclosure to trim the beam within the required shape and dimension.

3.3. View-port Glass

The Vendor shall provide the glass for the view-port area as per following table-6.

Table-6: Specification of table support

Sr No.	Specification / description	Specification value
1	View-port area	0.5 x 0.75 m ²
2	Glass Thickness	Specify. Minimum 6 mm
3	Material and Energy threshold	Specify. Shall be compatible with requirements of Sun simulator in section 3.1, with respect to transmission spectrum and temperature tolerance.

3.4. Stand for DUT with 4-DOF Motion Control:

The stand for DUT will be used for initial alignment and rotation of DUT during testing. It requires 3 translation motion (x-y-z) for aligning the DUT to Sun simulator beam and 1-axis azimuth rotation for rotating the DUT wrt the beam.

Table-2: Specification of Stand for DUT with 4-dof Motion Control

Sr No.	Specification / description	Specification value
1	Top stage of 4-dof motion	1-axis rotation stage (azimuth)
2	Bottom stage of 4-dof motion	3-axis translation stage (x-y-z)
3	Vertical translation range (z-axis)	1100-700 mm, manual control
4	Horizontal X and Y translation range	± 100 mm, manual control

5	Azimuth rotation range	± 180 deg, Remote controlled from User Console for Azimuth Rotation
6	Resolution of x-y-z translator	1 mm or better
7	Azimuth angular resolution	± 0.1 deg
8	Azimuth angular repeatability	± 0.1 deg
9	Maximum Load capacity (of the top rotary stage) for DUT	> 50 kg
10	Diameter of Rotary Stage to support DUT	400 mm (typical)
11	One-axis Rotary Stage consisting of (a) One-circle Goniometer (b) Stepper Motor (c) control system with PC interface (d) Stepper motor kit consisting of wiring, pre-configuration,	Required
12	Electrical interface for rotary stage	Shall specify. User console to rotary stage will be at 10m distance. Compatible interface should be provided. User control supports USB / Ethernet interface
13	Backlash free motion	Shall be provided
14	Column Material	Stainless Steel
15	Stand base with three point support with Castor wheels (Teflon coated) for easy movement	Shall be provided
16	Stand base with three levelling bolts for tilt adjustment	Shall be provided
17	Base levelling provision	Shall be provided
18	Centre of gravity of whole stage should be	within ± 5 mm from the column axis
19	Provide lock mechanism to arrest vertical movement	Suitable
20	Limit switches	To be included suitably
21	Power Input	230 \pm 20 V, 50 Hz
22	Construction Material	Aluminium alloy
23	Finish	Black anodized
24	Room Compatible	Clean room compatible (ISO 5)
25	Mechanical Interface	Specify details (Preferred M6 Tapped holes)

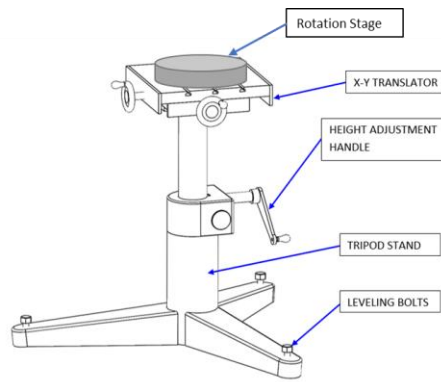

Fig-2: Representative Block diagram of the Stand for DUT with 4-dof Motion control

3.5. Light Absorbing Wall Sticker:

Clean room facility wall should ideally absorb all stray-lights falling on it, to create the dark condition by minimizing the reflections from the walls. Black stickers are to be pasted on the walls with the following specifications:

Table-4: Specification of light absorbing wall sticker

Sr No.	Specification / description	Specification value
1	Foil type	with good self-adhesion on metal wall
2	Reflectance in 300 – 900 nm wavelength	< 1%
3	Clean room compatible	ISO 5 standard
4	Humidity Resistance	MIL-C-48497A
5	Temperature range	10 – 40 °C
6	Total surface area to be covered	Approx. 110 m ²

3.6. Reference solar cell with digital meter

The Vendor shall provide a calibrated reference solar cell with digital meter as mentioned in table-5:

Table-5: Specification of Reference solar cell

Sr No.	Specification / description	Specification value
1	Description	A calibrated reference solar cell with digital meter required to measure source irradiance.
2	Measurement range	0-2 Solar Constant
3	Resolution	< 0.001 SC
4	Mode	Either open or shunt is acceptable. Suitable meter to be provided for readout.
5	Remote data logging	Shall provide suitable interface with cable for remote data logging in console at 8-10m distance.

4. **Acceptance test Plan:**

4.1. **Factory Acceptance Test (FAT):**

- 4.1.1. FAT for Sun simulator shall contain the performance data of the simulator with respect to (a) spectral match, (b) Irradiance measurement, (c) uniformity test, (d) temporal instability and other necessary performance parameters.
- 4.1.2. For the rest of the equipment, product details shall be shared with calibration or test data, wherever applicable.

4.2. **Site Acceptance Test (SAT) at LEOS:**

- 4.2.1. Acceptance test shall be performed after the installation of the setup at LEOS to establish satisfactory performance of the simulator.
- 4.2.2. The vendor shall submit the test procedure document and supporting items from LEOS well in advance prior to commencement of the acceptance tests.
- 4.2.3. Appropriate methods shall be adopted to conduct performance checks and shall not be limited to the procedures mentioned in table-7. Successful completion of the SAT will be the criteria for acceptance of the system at LEOS.

Table-7: SAT plan at LEOS

Sl. no.	Acceptance test	Test details
1	System Alignment	- Alignment of Sun simulator - Alignment of Sun simulator with DUT stand
2	Irradiance and uniformity test	Using a reference solar cell, the vendor has to measure irradiance and uniformity at the specified working distance (sl. no. 5 of table-1) and comply with the requirement.
3	Beam Diameter test	Beam diameter at the specified working distance (sl. no. 5 of table-1) should be measured and complied with the requirement.
4	Stability of Light Simulator	This test shall be carried out using calibrated reference solar-cell to measure the relative beam intensity over a period of 24 hours at every 1 hour interval.
5	One-axis Rotary test	This measurement shall be carried out to demonstrate total rotation capability from -90° to +90° in steps of 0.5° with given load. It will include the demonstration of console operation also.
6	Light Absorbing Wall Sticker fixing	Vendor should stick the inner wall of clean room with the black stickers supplied

5. WARRANTY:

- 5.1. **Standard Warranty shall be provided from the successful completion of SAT test at LEOS to the Purchaser for 1 year.** This should consist of telephone/e-mail support for liaison on minor trouble shooting problems and in case of major failures, return-to-base of the equipment for repair.
- 5.2. Optional quote for 3 years extended onsite comprehensive warranty after completion 1-year standard warranty.

6. INSTALLATION AND TRAINING:

- 6.1. The vendor is responsible for installation, acceptance test and training of the equipment after its delivery to LEOS premises.
- 6.2. The vendor shall furnish specification compliance test report of FAT to the purchaser's representative at the pre-shipment stage.
- 6.3. The vendor shall give intimation at least 1 month in advance, prior to installation at LEOS premises.
- 6.4. The vendor representative shall perform the complete installation and acceptance test (SAT) at purchaser's premises (LEOS) and provide necessary training for its usage. Training shall include cleaning of the lamp module, replacement of the lamp and other maintenance related activities.
- 6.5. The vendor shall inform at the time of order acceptance, the additional test equipment needed for conducting test and evaluation at purchaser's premises.

7. **DELIVERABLES & SCHEDULES**

7.1 Deliverables:

Table-8: Deliverables

Sr No.	Specification / description	Quantity
1	Sun simulator	1 set
2	View port Glass	1 no.
3	Stand for DUT with 4-dof Motion Control	1 no.
4	Light Absorbing Sticker for room wall	1 no.
5	Reference solar cell with digital meter	1 set
6	User Manual, Calibration report, Cable and Accessories	1 set
7	Spares and Accessories (optional)	1 set

7.2 Delivery schedule:

All the above items shall be supplied **within 12 months** from the date of Purchase order.

Installation and SAT test as per section 4.2 shall be completed **within 3 months** from the received date of all the deliverables.

7.3 Spare parts Requirements:

- a. A list of all spares to be furnished with detailed specifications and quantity recommended for 5 years of operation.
- b. The vendor should support with respect to sales and services, and also hold the prices for the spares for extended period.

8. **Packaging & Shipping**

- 8.1. Each component/ equipment should be packaged in order to protect against mechanical damages with extreme environmental conditions in transit or transportation.
- 8.2. The documentation should be enclosed in the shipping package.

9. **Previous Experience**

Details of at least one previous supply / installations similar to this system that has been supplied /installed at any organization / industries should be mentioned with documentary proof.

10. Quote format

Quotations should be sent in two sealed cover for 2 part submission: (1) Technical and (2) Commercial. Format for quote submission is explained here.

10.1. Technical quote (Format-1)

All the vendors have to submit the Format-1 (with related technical documents) failing which, their quotations will not be considered.

SL no	Parameter	Vendor compliance
1	Compliance to Sec 3	(a) Compliance for each table (1 to 6) to be mentioned with achievable specs (b) Configuration diagram of Sun simulator design
2	Compliance to Sec 4	Compliance for all points including table-7 to be mentioned with both FAT and SAT test plan.
3	Compliance to Sec 5	Fully complied / Not complied
4	Compliance to Sec 6	Compliance for all points to be mentioned
5	Compliance to Sec 7	Fully complied / Not complied
6	Compliance to Sec 8	Fully complied / Not complied
7	Compliance to Sec 9	Fully complied / Not complied

10.2. Commercial quote (Format-2)

All the vendors have to submit the Format-2 failing which, their quotations will not be considered

Sl no	Items*	Unit	Unit Rate	Qty	Amount	Remarks
1	Supply and installation of equipment for Wide-beam Sun Simulator Facility	Set		01		
Spares and Accessories						
2	Spare lamp	slabs		1-3, 4-7, 8-15		optional
3	Lamp power supply and ignitor	No.		01		optional
4	Extended onsite comprehensive warranty	years		03		optional
5	Critical spares for 5 years, If any	Nos.				optional

*Note: L1 vendor will be evaluated based on quote for item in sl. no. 1 only.