

## Annexure - I b

### Scope of Work for Augmentation of AV facility in 6 Conference halls at LPSC (V)

Supply, installation and configuration of the following items (listed in Table 1) for Nila Conference Hall, as per the specifications attached. Establishing connectivity as shown in Fig. 1 a and Fig. 1 b in the hall. The dimensions of the hall are shown in Fig. 1 c.

**Table 1:** List of AV items required for Nila Conference Hall

<b>Nila Conference Hall</b>		
<b>Sl. No.</b>	<b>Item Name</b>	<b>Qty</b>
1	Table top boundary microphones with LED status indicator & mute button	15
2	Audio DSP solution (24 input, 16 output)	1
3	4 channel Power Amplifier	1
4	Ceiling mount loudspeaker	6
5	USB 3.0 peripheral sharing switch	1
6	8 input, 8 output HDMI Matrix switcher	1
7	HDMI Scaler	1
8	HDBT Txr with PoE	4
9	HDBT Rxr with PoE	4
10	1*4 HDMI Distribution amplifier	1
11	Chairman monitor	1
12	Tab Tension Motorized projector screen with remote controller	1
13	HDMI to USB capture Box	2
14	USB extender Kit	2
15	HDMI Table Flip box for Laptop	1
16	Display port (Male) to HDMI (Female) Adapter / Adapter cable	2
17	USB Type-C (Male) to HDMI (Female) Adapter / Adapter cable	2
18	HDMI (Female) to DVI-D (Male) Adapter / Adapter cable	2
19	DVI-D (Male) to HDMI (Female) Adapter / Adapter cable	2
20	Wireless Keyboard & Mouse	2
21	AA Rechargeable Battery	10
22	AAA Rechargeable Battery	10
23	Battery charger for AA & AAA Rechargeable Batteries	2
24	19 inch AV rack (18 U)	1

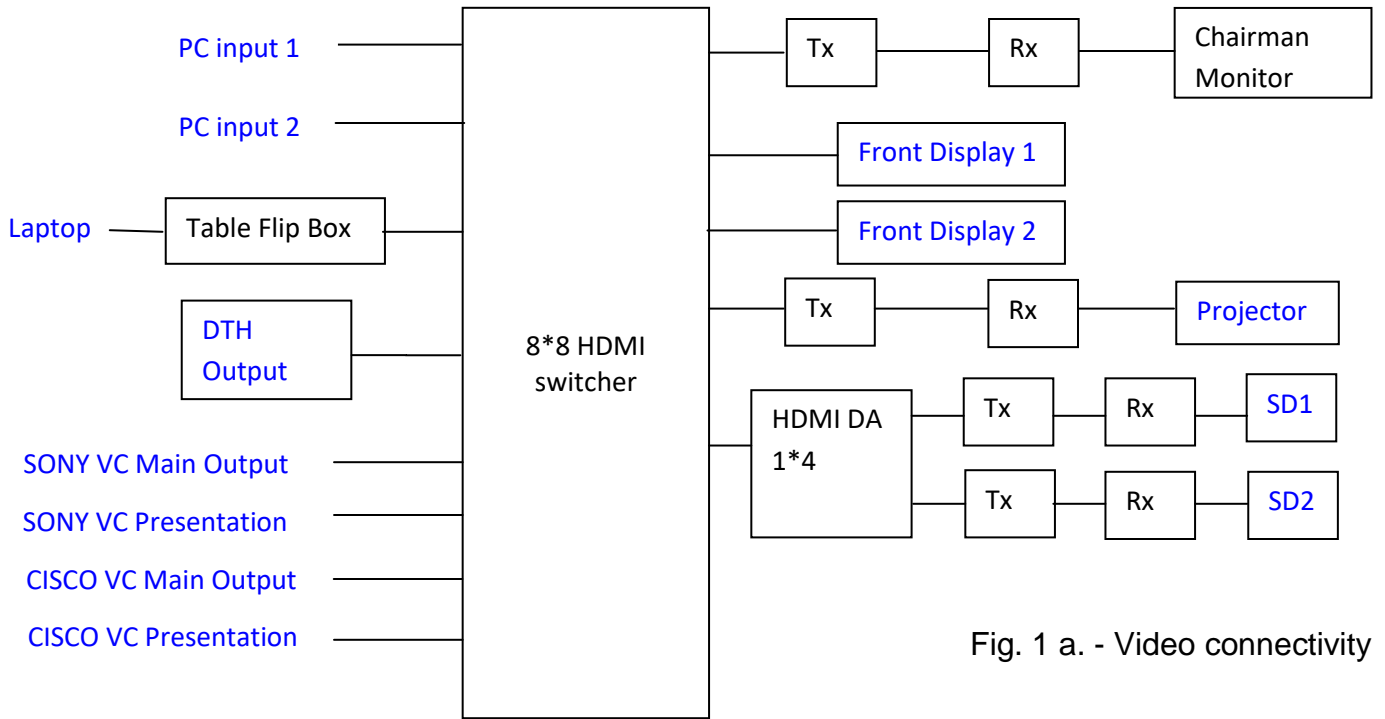

Fig. 1 a. - Video connectivity

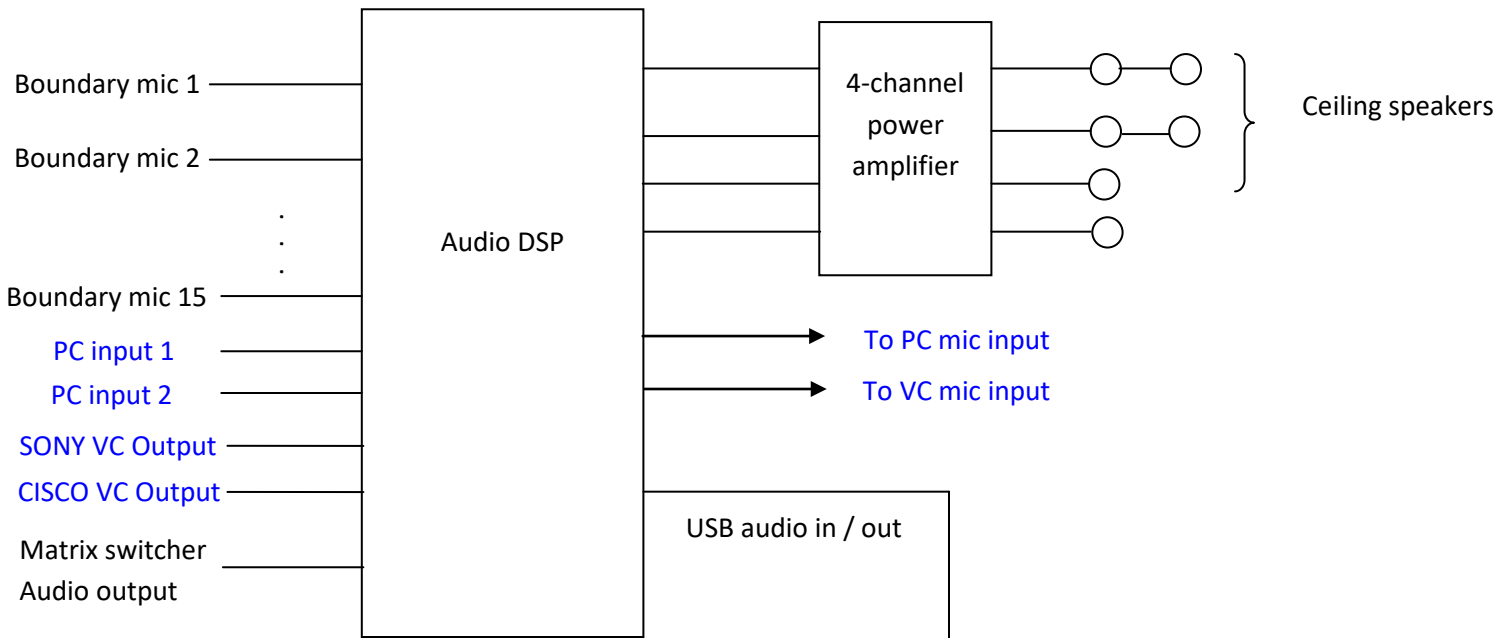
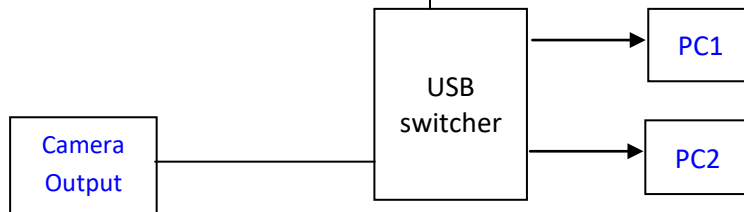

Fig. 1 b. - Audio connectivity



Existing equipment

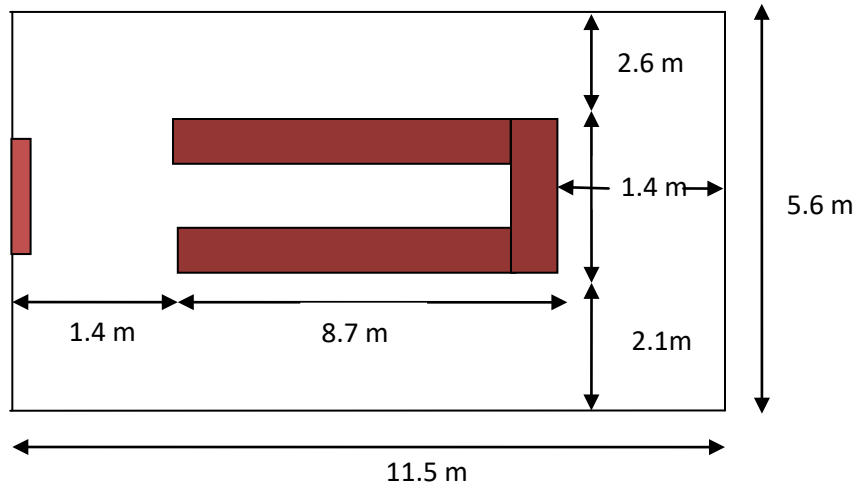

Fig. 1 c. - Dimensions of Nila conference hall

- Supply, installation and configuration of the following items (listed in Table 2) for Kaveri Conference Hall, as per the specifications attached. Establishing connectivity as shown in Fig. 2 a and Fig. 2 b in the hall. The dimensions of the hall are shown in Fig. 2 c.

**Table 2:** List of AV items required for Kaveri Conference Hall

Kaveri Conference Hall		
Sl. No.	Item Name	Qty
1	Table top boundary microphones with LED status indicator & mute button	15
2	Audio DSP solution (24 input, 16 output)	1
3	4 channel Power Amplifier	1
4	Ceiling mount loudspeaker	6
5	USB 3.0 peripheral sharing switch	1
6	8 input, 8 output HDMI Matrix switcher	1
7	HDMI Scaler	1
8	HDBT Txr with PoE	4
9	HDBT Rxr with PoE	4
10	1*4 HDMI Distribution amplifier	1
11	Chairman monitor	1
12	Tab Tension Motorized projector screen with remote controller	1
13	HDMI to USB capture Box	2
14	USB extender Kit	2
15	HDMI Table Flip box for Laptop	1
16	Display port (Male) to HDMI (Female) Adapter / Adapter cable	2
17	USB Type-C (Male) to HDMI (Female) Adapter / Adapter cable	2
18	HDMI (Female) to DVI-D (Male) Adapter / Adapter cable	2
19	DVI-D (Male) to HDMI (Female) Adapter / Adapter cable	2
20	Wireless Keyboard & Mouse	2
21	AA Rechargeable Battery	10
22	AAA Rechargeable Battery	10
23	Battery charger for AA & AAA Rechargeable Batteries	2
24	19 inch AV rack (18 U)	1

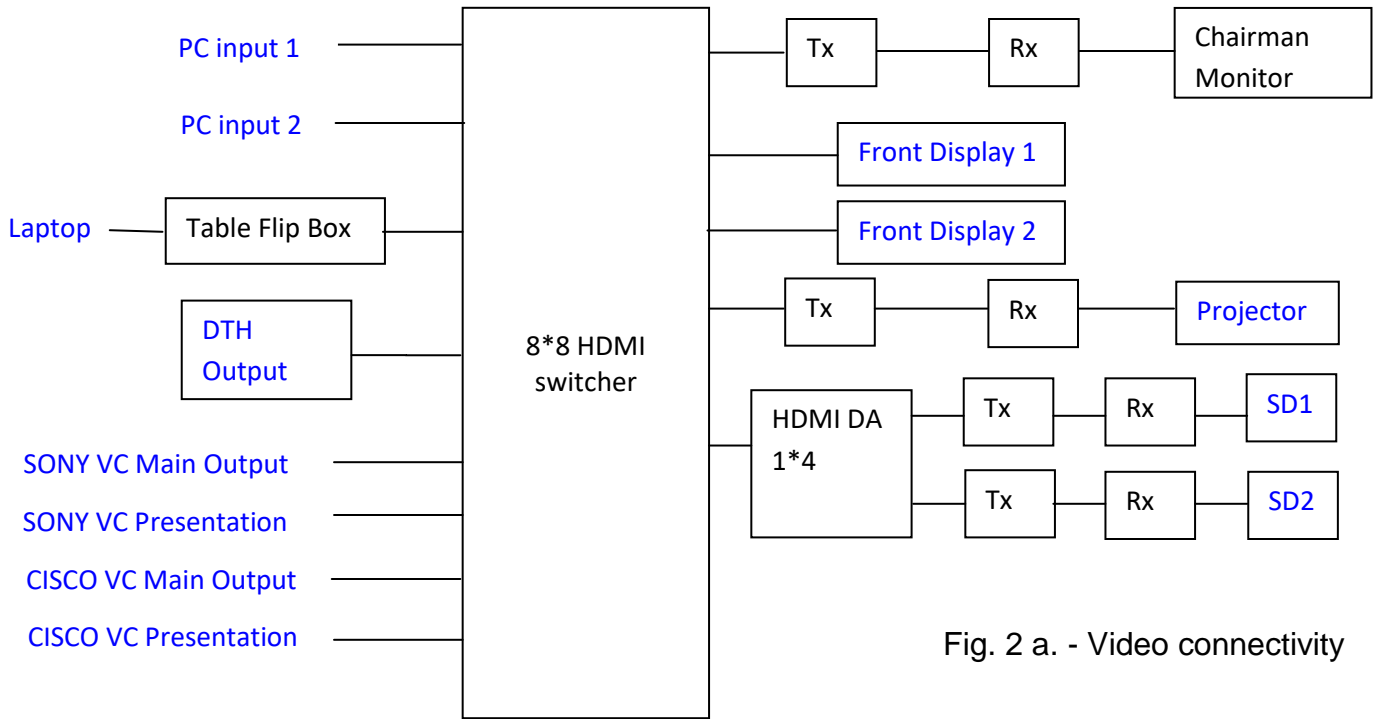

Fig. 2 a. - Video connectivity

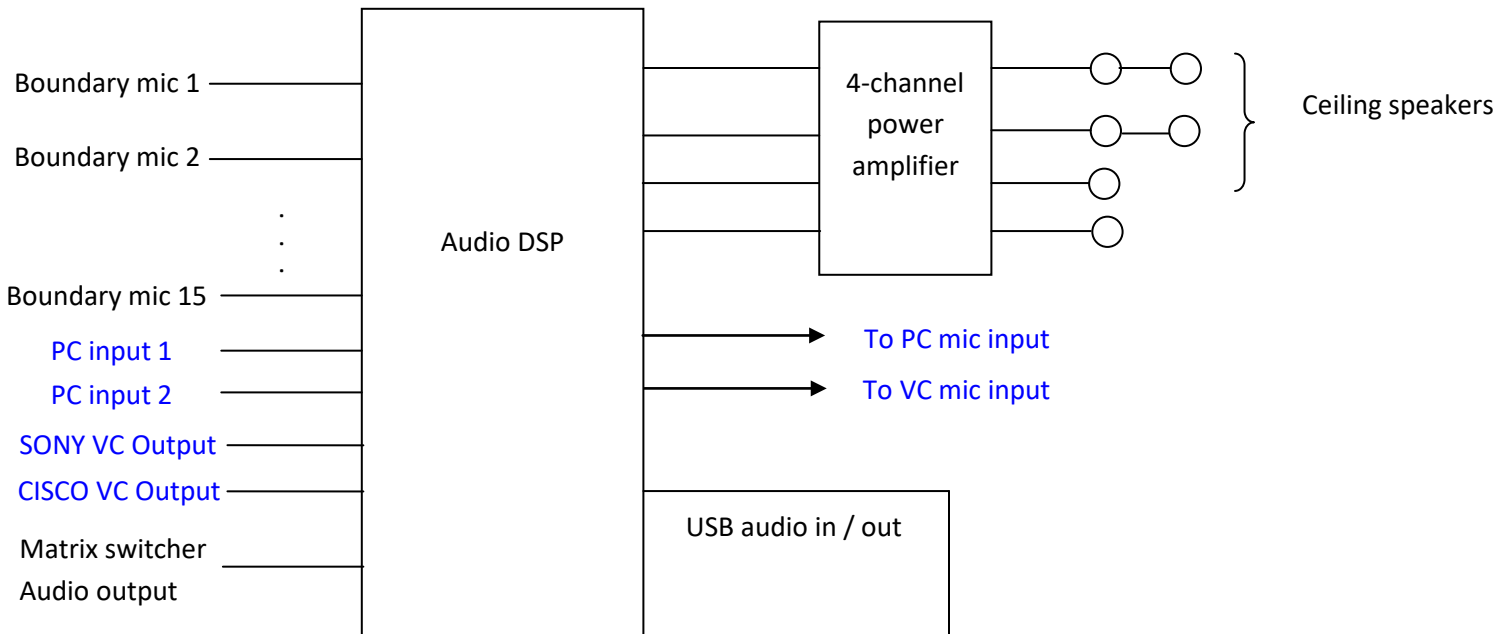

Fig. 2 b. - Audio connectivity

■ — Existing equipment

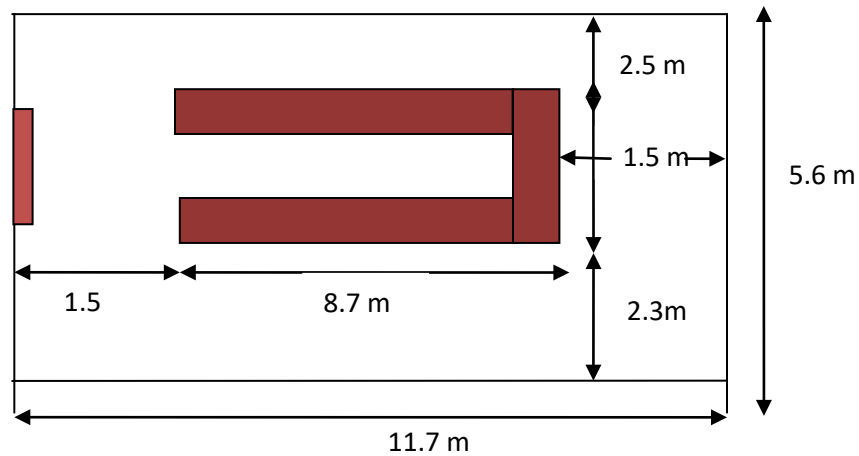

Fig. 2 c. - Dimensions of Kaveri conference hall

- Supply, installation and configuration of the following items (listed in Table 3) for Godavari Conference Hall, as per the specifications attached. Establishing connectivity as shown in Fig. 3 a and Fig. 3 b in the hall. The dimensions of the hall are shown in Fig. 3 c.

**Table 3:** List of AV items required for Godavari Conference Hall

Godavari Conference Hall		
Sl. No.	Item Name	Qty
1	Table top boundary microphones with LED status indicator & mute button	13
2	Audio DSP solution (16 input, 8 output)	1
3	4 channel Power Amplifier	1
4	Ceiling mount loudspeaker	4
5	USB 3.0 peripheral sharing switch	1
6	4 input, 4 output HDMI Matrix switcher	1
7	HDMI Scaler	1
8	HDBT Txr with PoE	2
9	HDBT Rxr with PoE	2
10	Chairman monitor	1
11	USB extender Kit	2
12	HDMI Table Flip box for Laptop	1
13	Display port (Male) to HDMI (Female) Adapter / Adapter cable	2
14	USB Type-C (Male) to HDMI (Female) Adapter / Adapter cable	2
15	Wireless Keyboard & Mouse	2
16	AA Rechargeable Battery	10
17	AAA Rechargeable Battery	10
18	Battery charger for AA & AAA Rechargeable Batteries	2
19	19 inch AV rack (15 U)	1

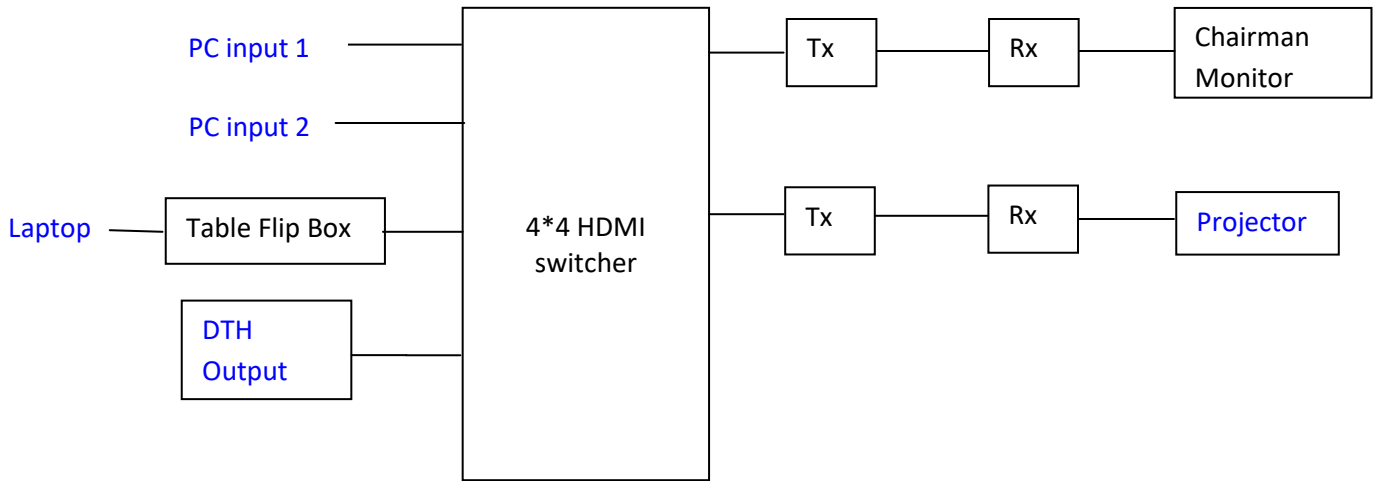

Fig. 3 a. - Video connectivity

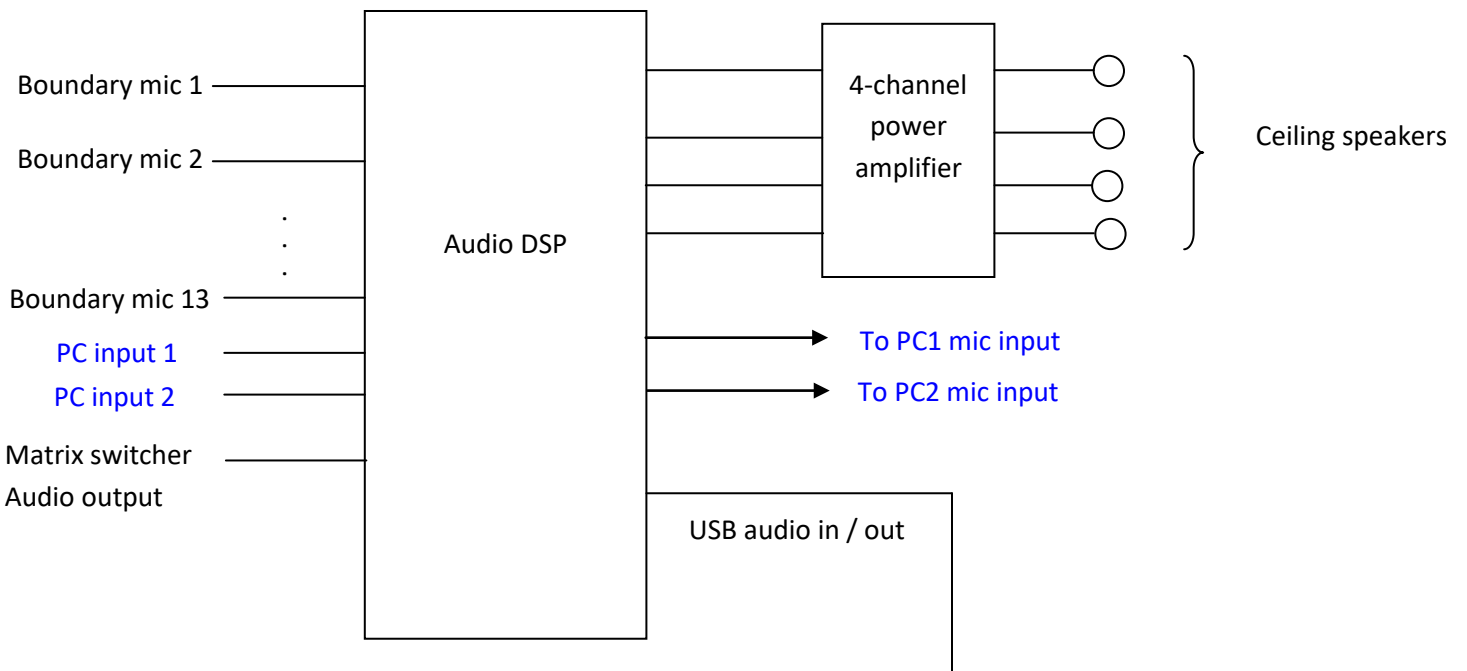
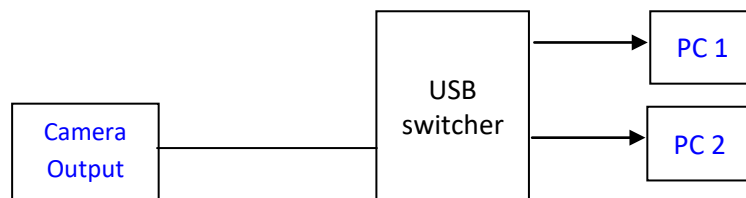

Fig. 3 b. - Audio connectivity



Existing equipment

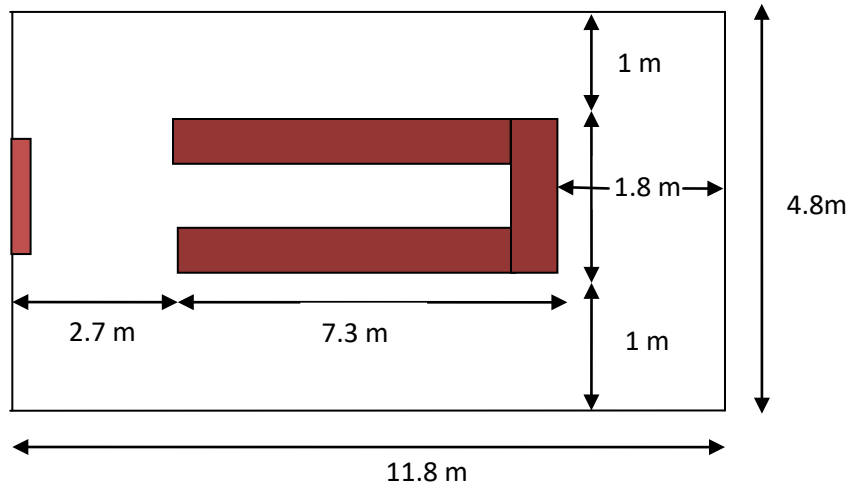

Fig. 3 c. - Dimensions of Godavari conference hall

- Supply, installation and configuration of the following items (listed in Table 4) for Kairali Conference Hall, as per the specifications attached. Establishing connectivity as shown in Fig. 4 a and Fig. 4 b in the hall. The dimensions of the hall are shown in Fig. 4 c.

**Table 4:** List of AV items required for Kairali Conference Hall

Kairali Conference Hall		
Sl. No.	Item Name	Qty
1	Table top boundary microphones with LED status indicator & mute button	7
2	Audio DSP solution (12 input, 8 output)	1
3	2 channel Power Amplifier	1
4	Ceiling mount loudspeaker	4
5	USB 3.0 peripheral sharing switch	1
6	4 input, 4 output HDMI Matrix switcher	1
7	HDBT Txr with PoE	1
8	HDBT Rxr with PoE	1
9	HDMI Table Flip box for Laptop	1
10	Display port (Male) to HDMI (Female) Adapter / Adapter cable	2
11	USB Type-C (Male) to HDMI (Female) Adapter / Adapter cable	2
12	Tab Tension Motorized projector screen with remote controller	1
13	Wireless Keyboard & Mouse	2
14	AA Rechargeable Battery	10
15	AAA Rechargeable Battery	10
16	Battery charger for AA & AAA Rechargeable Batteries	2
17	19 inch AV rack (15 U)	1

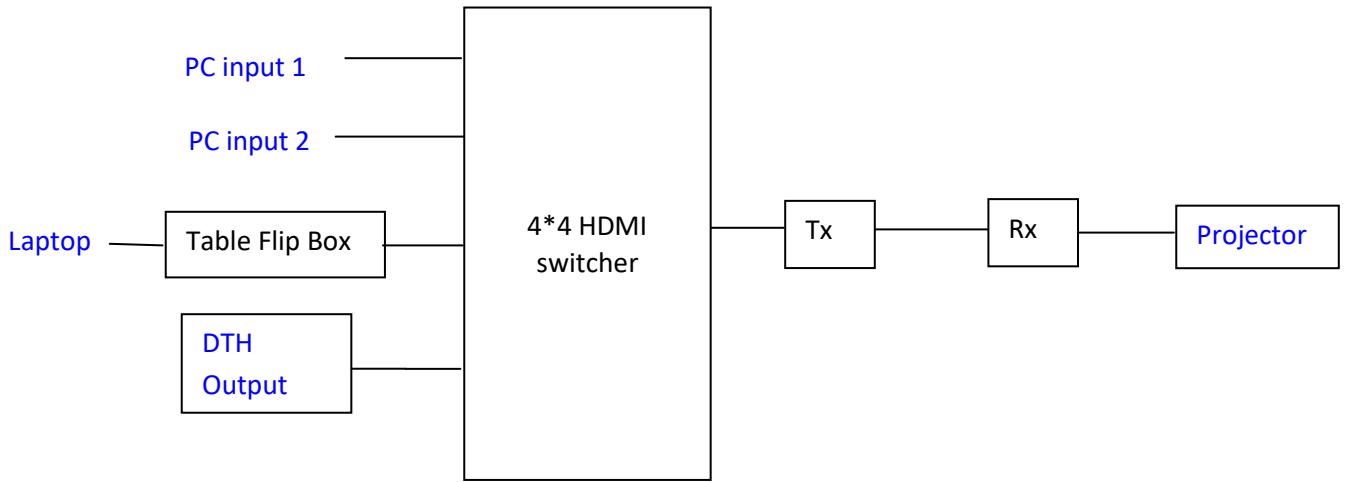

Fig. 4 a. - Video connectivity

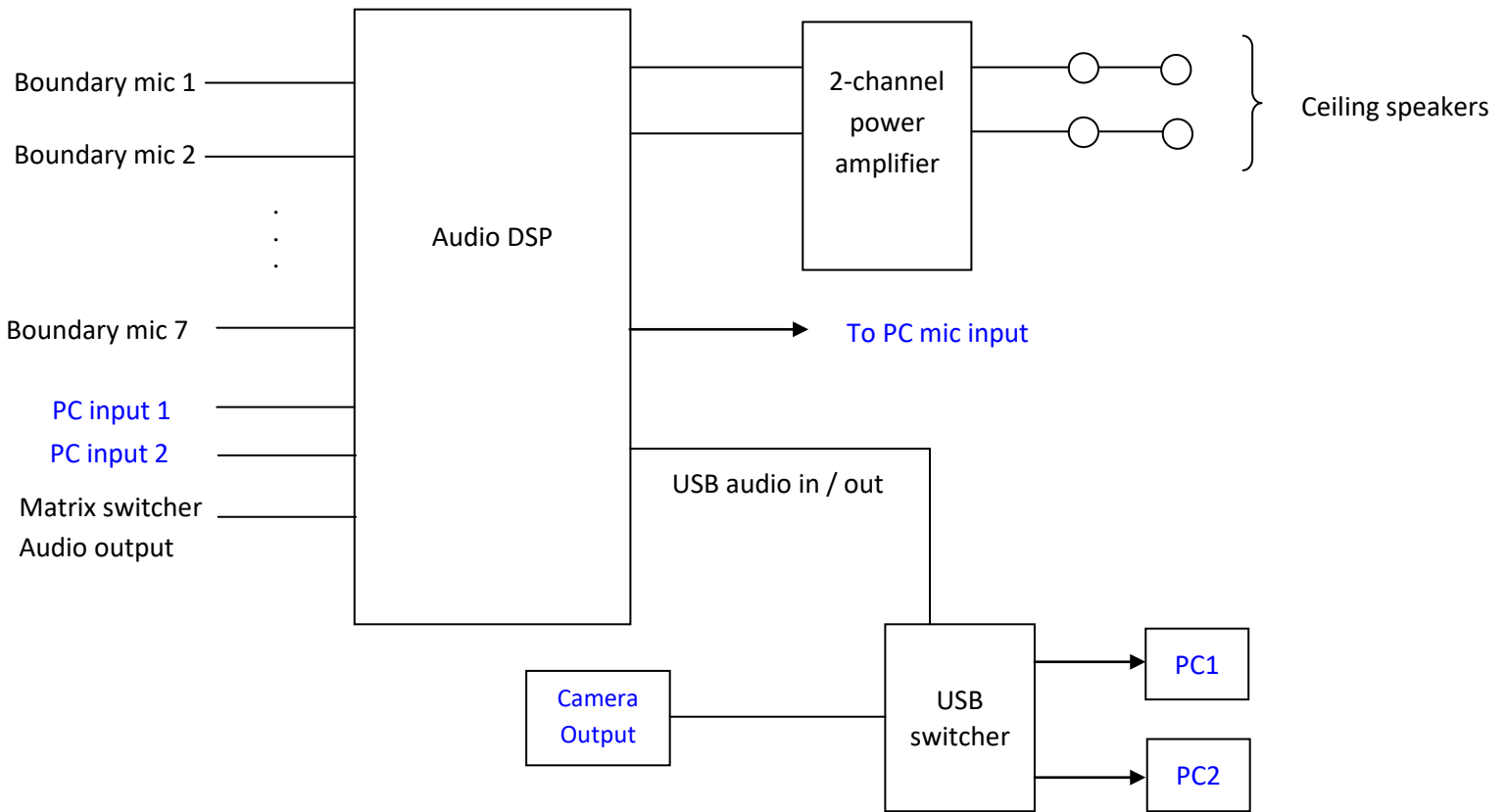

Fig. 4 b. - Audio connectivity

Existing equipment



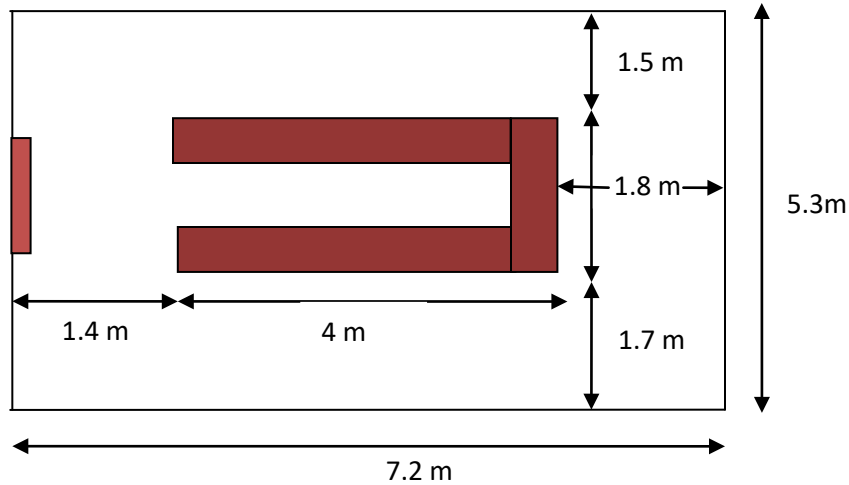

Fig. 4 c. - Dimensions of Kairali conference hall

- Supply, installation and configuration of the following items (listed in Table 5) for Prashasan Conference Hall, as per the specifications attached. Establishing connectivity as shown in Fig. 5 a and Fig. 5 b in the hall. The dimensions of the hall are shown in Fig. 5 c.

**Table 5:** List of AV items required for Prashasan Conference Hall

Prashasan Conference Hall		
Sl. No.	Item Name	Qty
1	Table top boundary microphones with LED status indicator & mute button	7
2	Wireless Handheld microphone with transmitter and receiver unit	2
3	Audio DSP solution (16 input, 8 output)	1
4	4 channel Power Amplifier	1
5	Ceiling mount loudspeaker	4
6	USB 3.0 peripheral sharing switch	1
7	8 input, 8 output HDMI Matrix switcher	1
8	HDMI Table Flip box for Laptop	1
9	Display port (Male) to HDMI (Female) Adapter / Adapter cable	2
10	USB Type-C (Male) to HDMI (Female) Adapter / Adapter cable	2
11	VGA to HDMI converter	2
12	Tab Tension Motorized projector screen with remote controller	1
13	Wireless Keyboard & Mouse	2
14	AA Rechargeable Battery	10
15	AAA Rechargeable Battery	10
16	Battery charger for AA & AAA Rechargeable Batteries	2
17	19 inch AV rack (15 U)	1

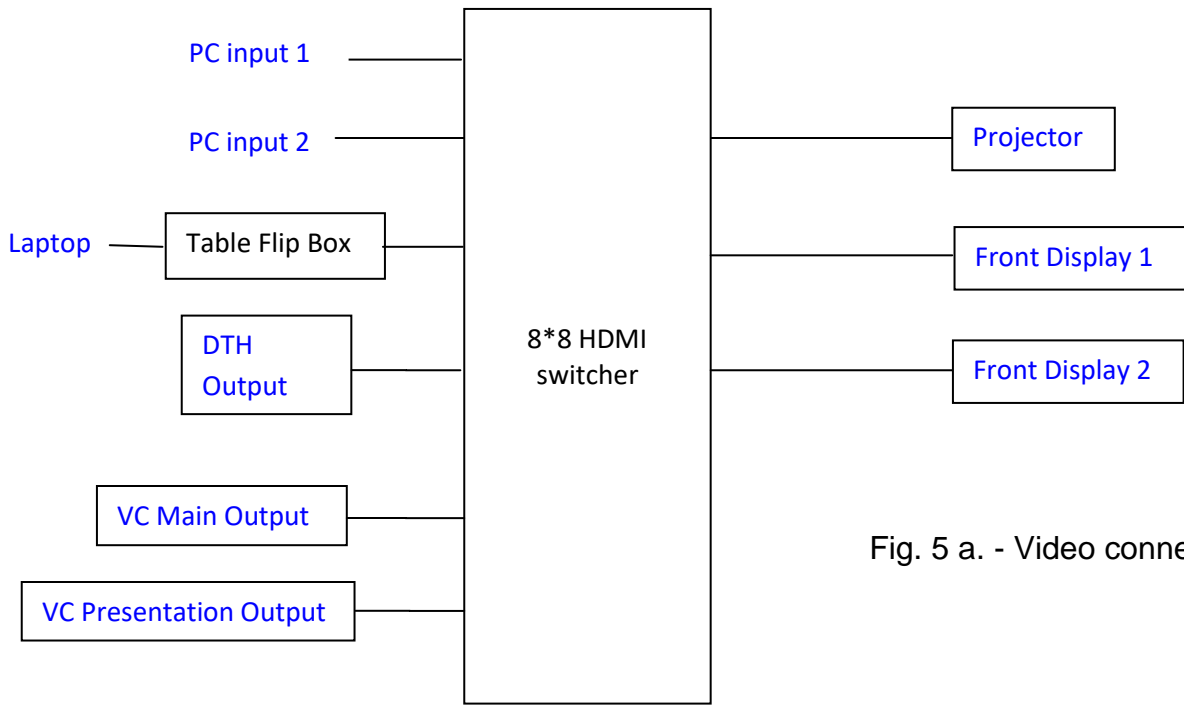

Fig. 5 a. - Video connectivity

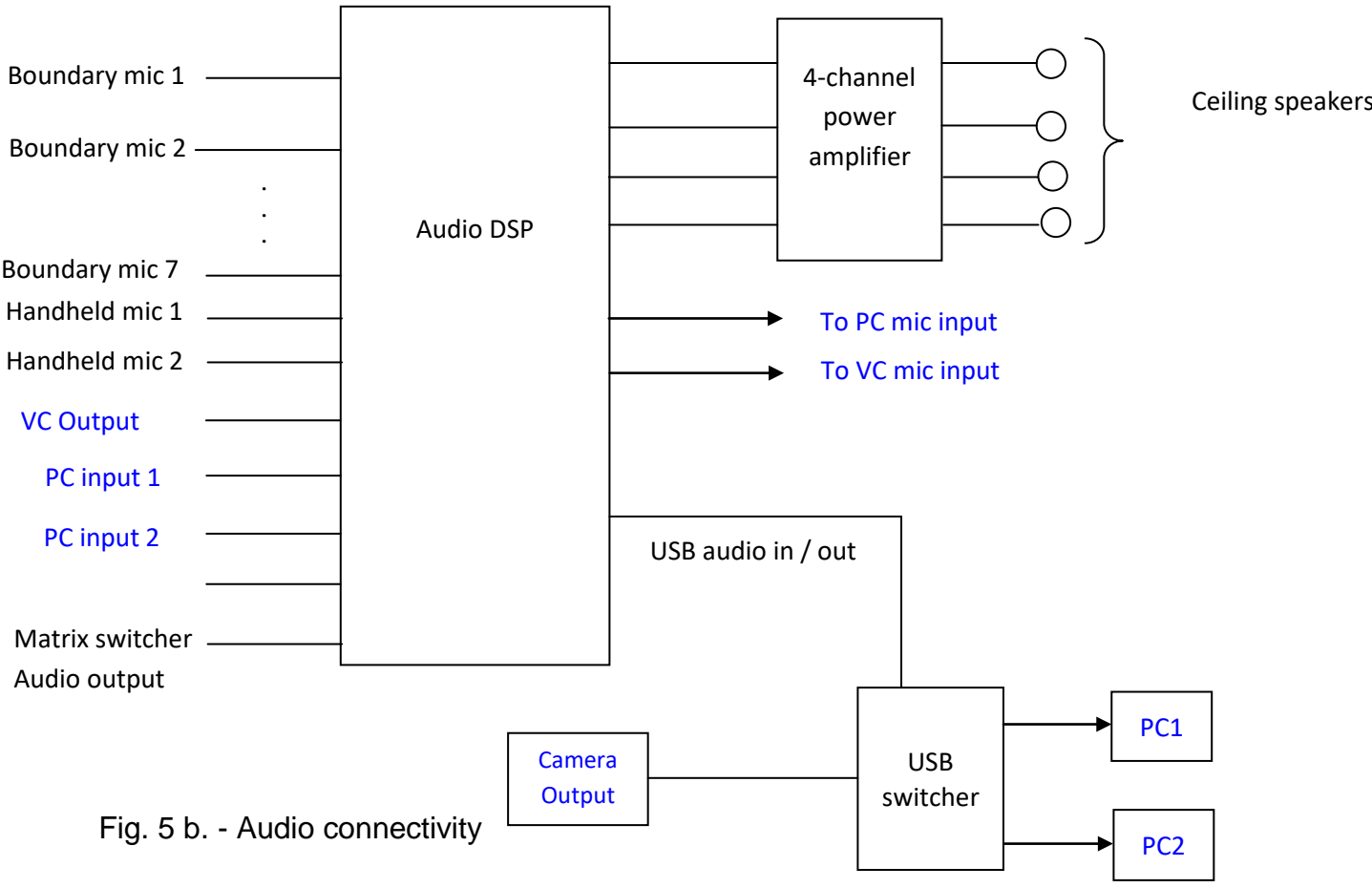

Fig. 5 b. - Audio connectivity

■ Existing equipment

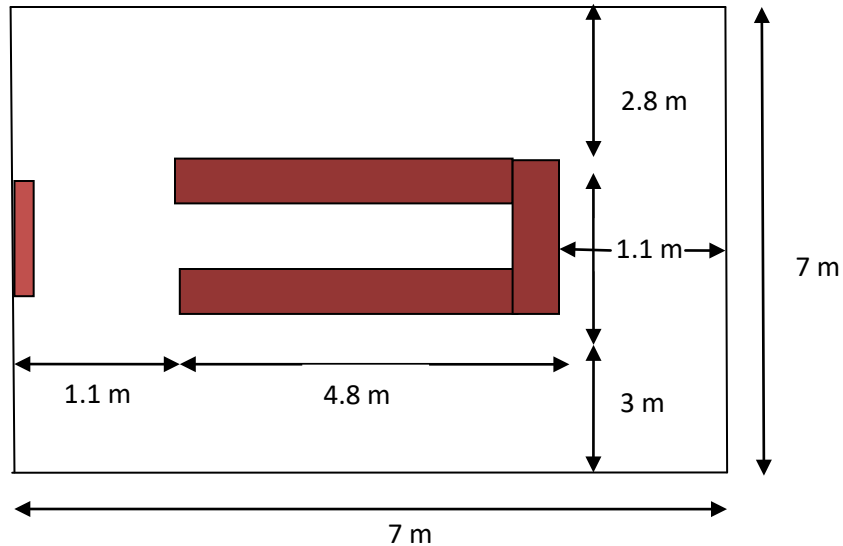

Fig. 5 c. - Dimensions of the conference hall

- Supply, installation and configuration of the following items (listed in Table 6) for Aditya Conference Hall, as per the specifications attached. Establishing connectivity as shown in Fig. 6 a and Fig. 6 b in the hall. The dimensions of the hall are shown in Fig. 6 c.

**Table 6:** List of AV items required for Aditya Conference Hall

<b>Aditya Conference Hall</b>		
<b>Sl. No.</b>	<b>Item Name</b>	<b>Qty</b>
1	Table top boundary microphones with LED status indicator & mute button	7
2	Audio DSP solution (12 input, 8 output)	1
3	4 channel Power Amplifier	1
4	Ceiling mount loudspeaker	4
5	USB 3.0 peripheral sharing switch	1
6	8 input, 8 output HDMI Matrix switcher	1
7	HDMI Table Flip box for Laptop	1
8	Display port (Male) to HDMI (Female) Adapter / Adapter cable	2
9	USB Type-C (Male) to HDMI (Female) Adapter / Adapter cable	2
10	Tab Tension Motorized projector screen with remote controller	1
11	Wireless Keyboard & Mouse	2
12	AA Rechargeable Battery	10
13	AAA Rechargeable Battery	10
14	Battery charger for AA & AAA Rechargeable Batteries	2
15	19 inch AV rack (15 U)	1

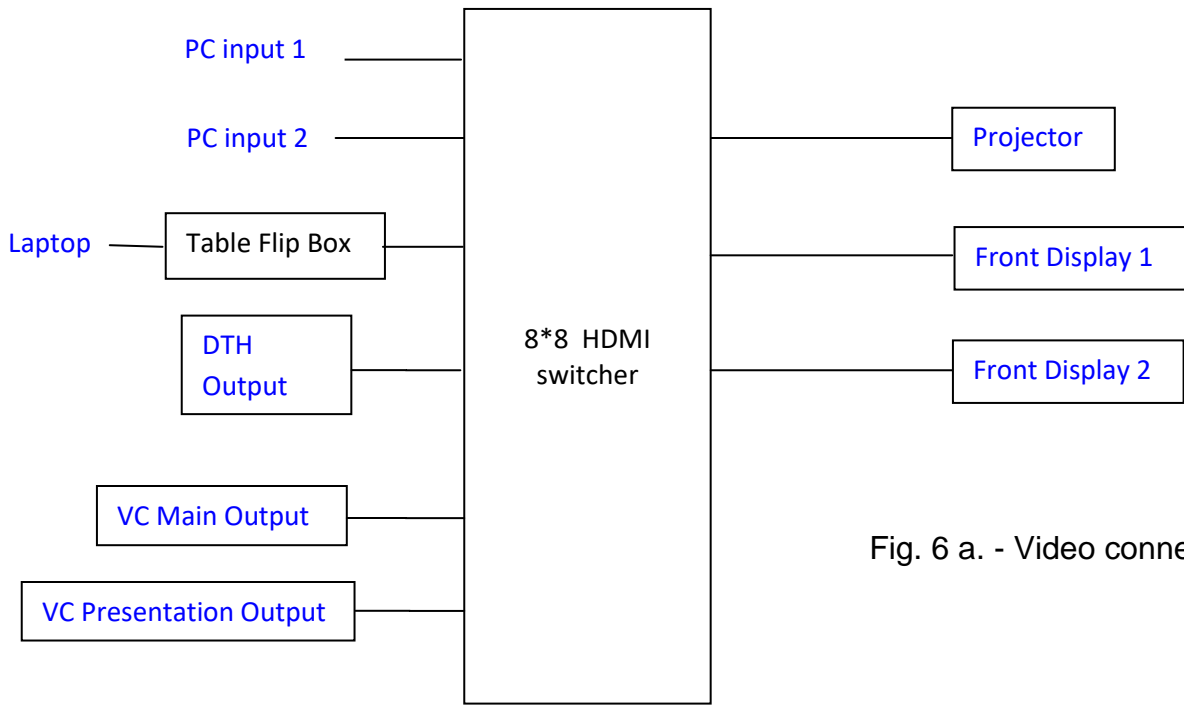

Fig. 6 a. - Video connectivity

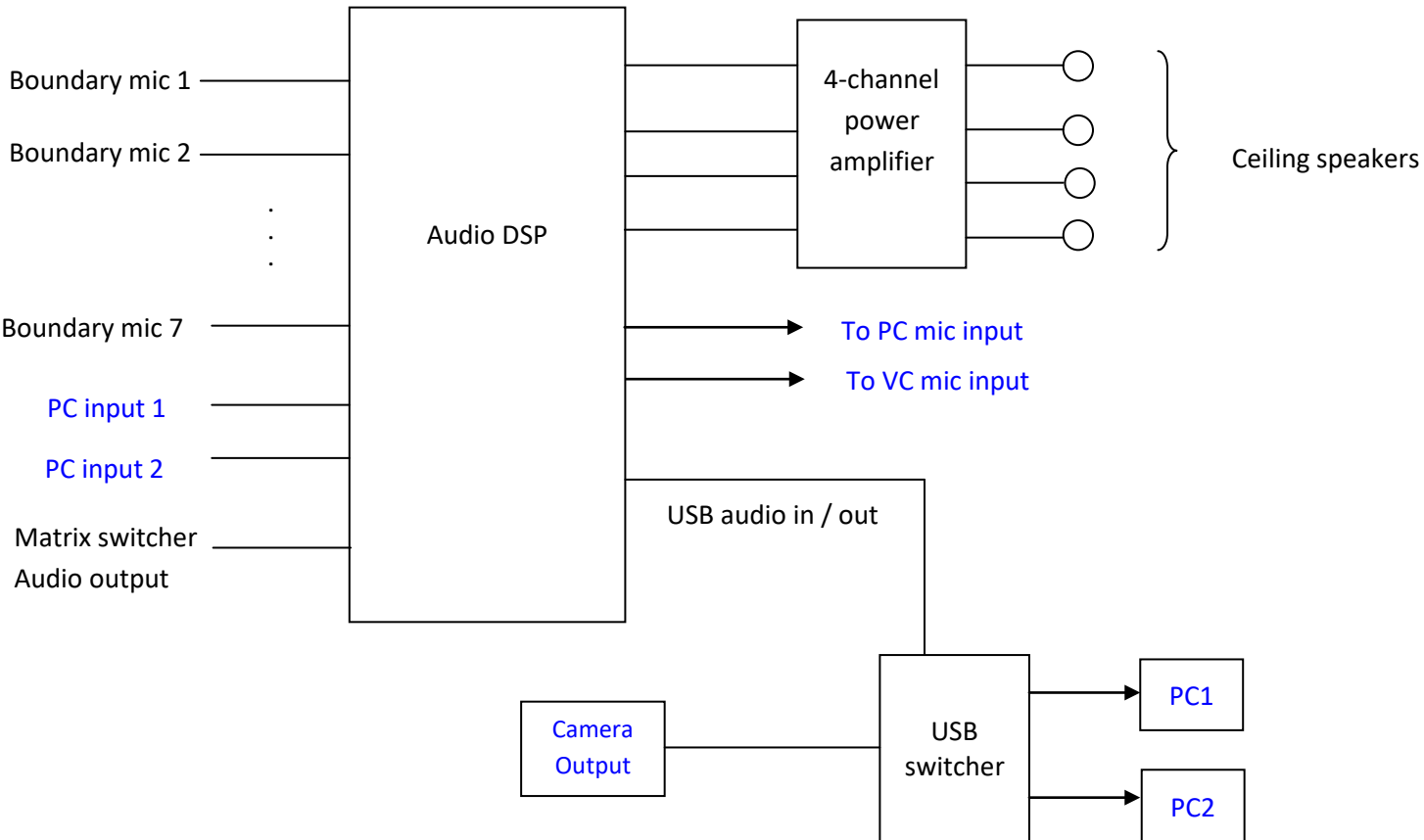

Fig. 6 b. - Audio connectivity

Existing equipment

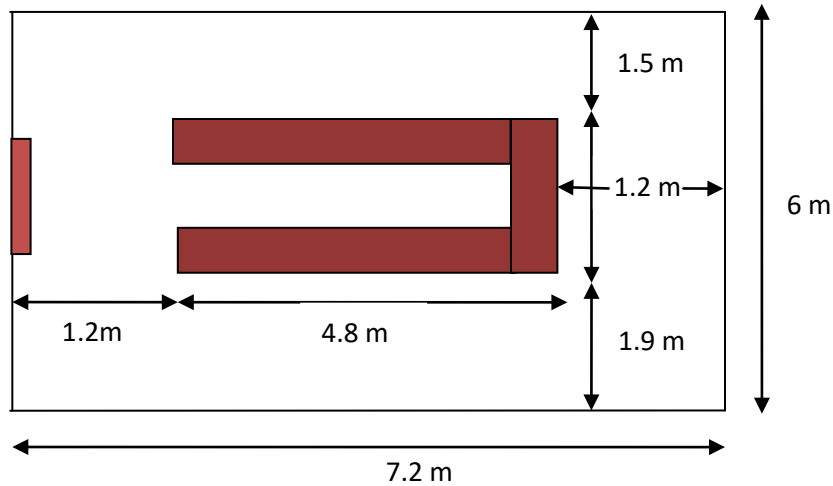

Fig. 6 c. - Dimensions of the conference hall

Essential Spare Items		
Sl. No.	Item	Qty
1.	Table top boundary microphones with LED status indicator & mute button	6
2.	Audio DSP solution (12 input, 8 output)	2
3.	4 channel Power Amplifier	1
4.	Ceiling mount loudspeaker	4
5.	8 input, 8 output HDMI Matrix switcher	2
6.	1*4 HDMI Distribution amplifier	8
7.	Tab Tension Motorized projector screen with remote controller	3
8.	HDBT Txr with PoE	5
9.	HDBT Rxr with PoE	5

HDMI cables, USB Cables and CAT6A cable for installation		
Sl. No	Item Name	Qty
1	HDMI cable- 3 feet	30
2	HDMI cable- 6 feet	30
3	HDMI cable- 10 feet	30
4	HDMI cable- 15 feet	30
5	HDMI cable- 25 feet	20
6	HDMI cable- 35 feet	20
7	USB 3.0 cable Type-A to Type-B (3 feet)	20
8	USB 3.0 cable Type-A to Type-B (6 feet)	20
9	USB 3.0 cable Type-A to Type-A (6 feet)	20
10	USB 3.0 Active Extender cable (25 Feet)	10
11	USB 3.0 Active Extender cable (35 Feet)	10
12	CAT 6A Shielded Ethernet Cable (300 meter)	1
13	Shielded RJ45 Connector	40

<b>Installation and commissioning</b>		
1	Audio cables and Mic Cables (Mono Balanced cable with 20 AWG or less gauge stranded Tinned Copper conductors should be used) and Speaker Cables (Plenum rated cable with 16 AWG or lesser gauge stranded Copper conductors should be used) and HDMI cables (4K @60Hz, 17Gbps) and CAT 6 UTP cables and CAT 6A Shielded Ethernet Cable and USB cables and other cables and cable extenders and Connectors and Converters and Wall mount brackets and Rack mount brackets and other accessories required for installation	6 lots

- The necessary audio/video cables and connectors and converters and wall mount brackets and rack mount brackets and consumables and other accessories required for the installation and integration with existing facility has to be supplied.
- The necessary PVC conduits, casing & capping and other cable management accessories for microphone cable, speaker cable, and other cables etc. required for the installation and integration with existing facility has to be supplied.
- 1 inch size Table Grommet Hole cover of metal has to be supplied and installed for each microphone
- Necessary Spare Mic Cable and speaker cable and audio / Video cables with connectors terminated at both ends should be provided as per LPSC Requirement.