

THIS DRAWING AND SPECIFICATIONS ARE THE PROPERTY OF THE SPACE APPLICATIONS CENTRE DEPARTMENT OF SPACE GOVERNMENT OF INDIA, AHMEDABAD AND SHALL NOT BE REPRODUCED OR COPIED OR USED AS THE BASE FOR THE MANUFACTURE OR SALE OF APPARATUS OR DEVICES WITHOUT PRIOR PERMISSION.

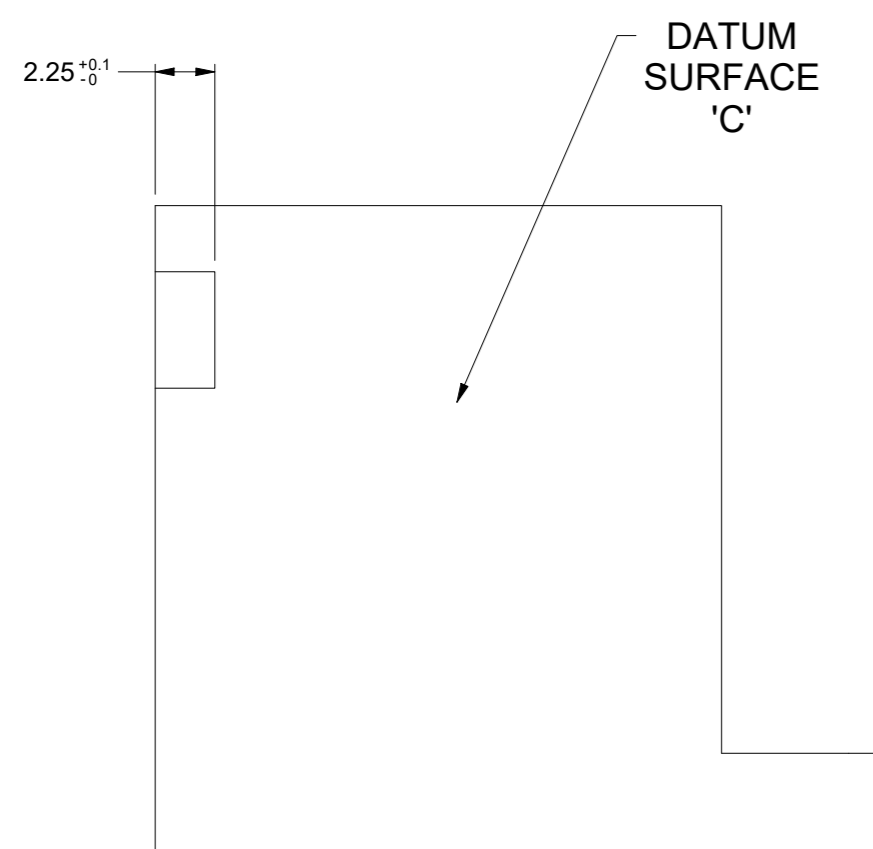

REAR VIEW

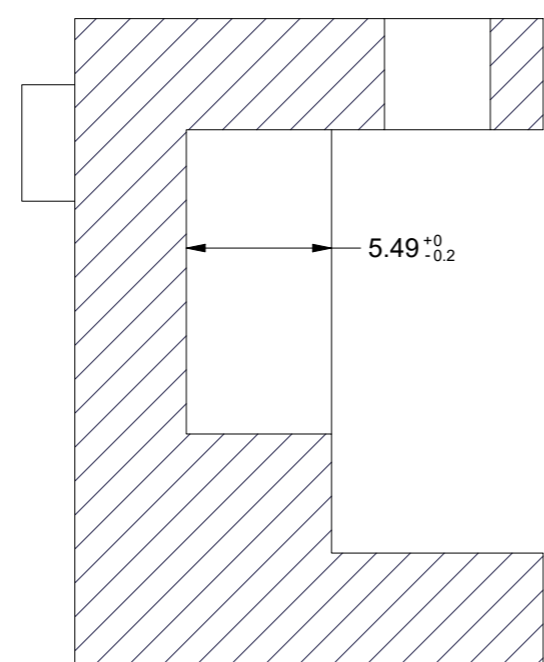

SECTION: A-A

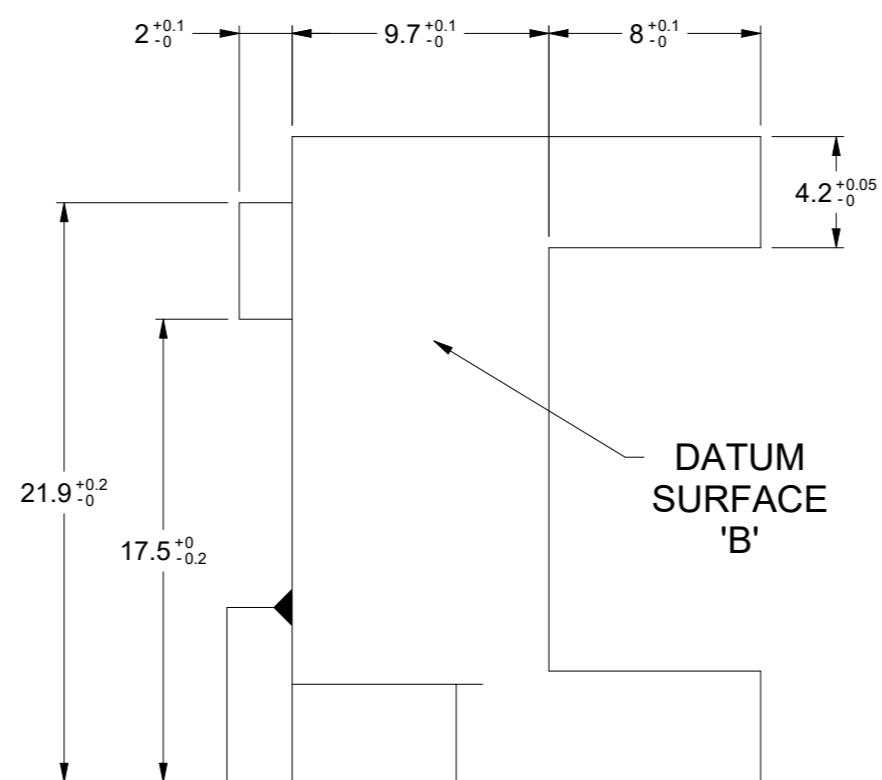

LEFT SIDE VIEW

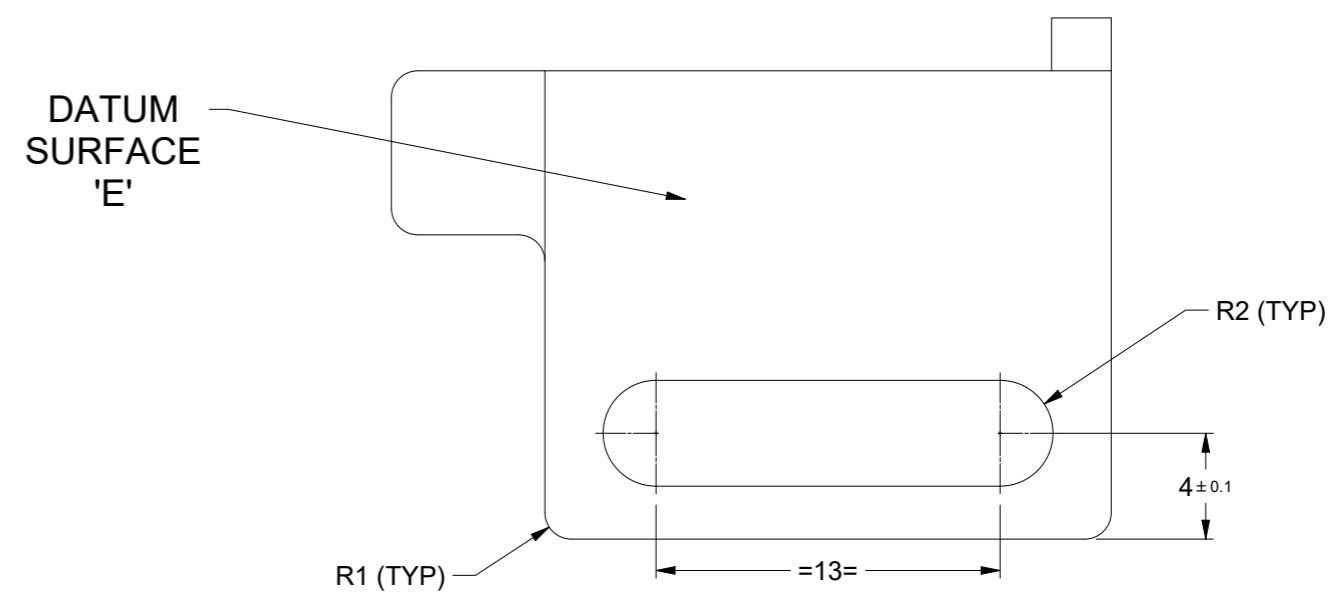

TOP VIEW

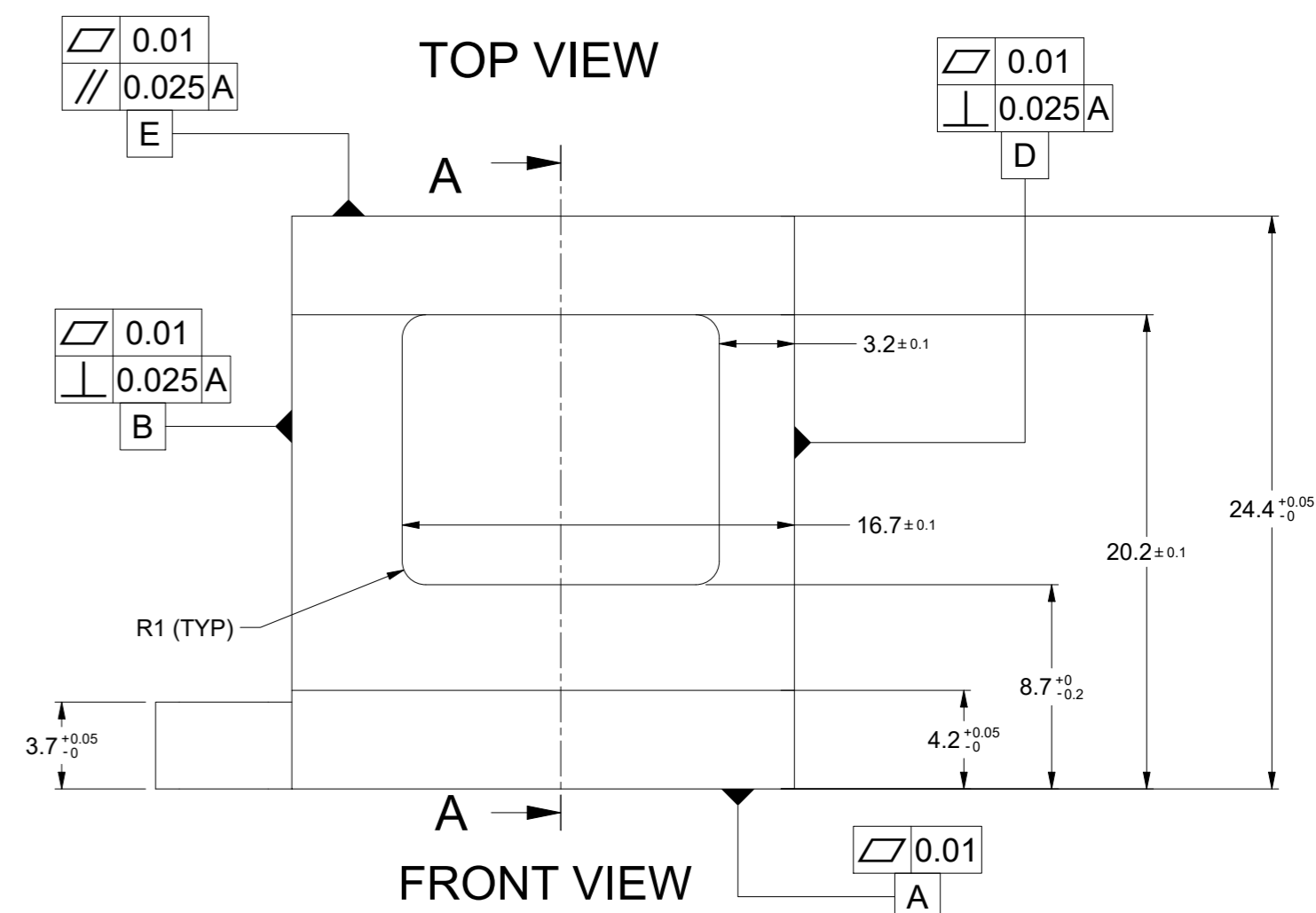

FRONT VIEW

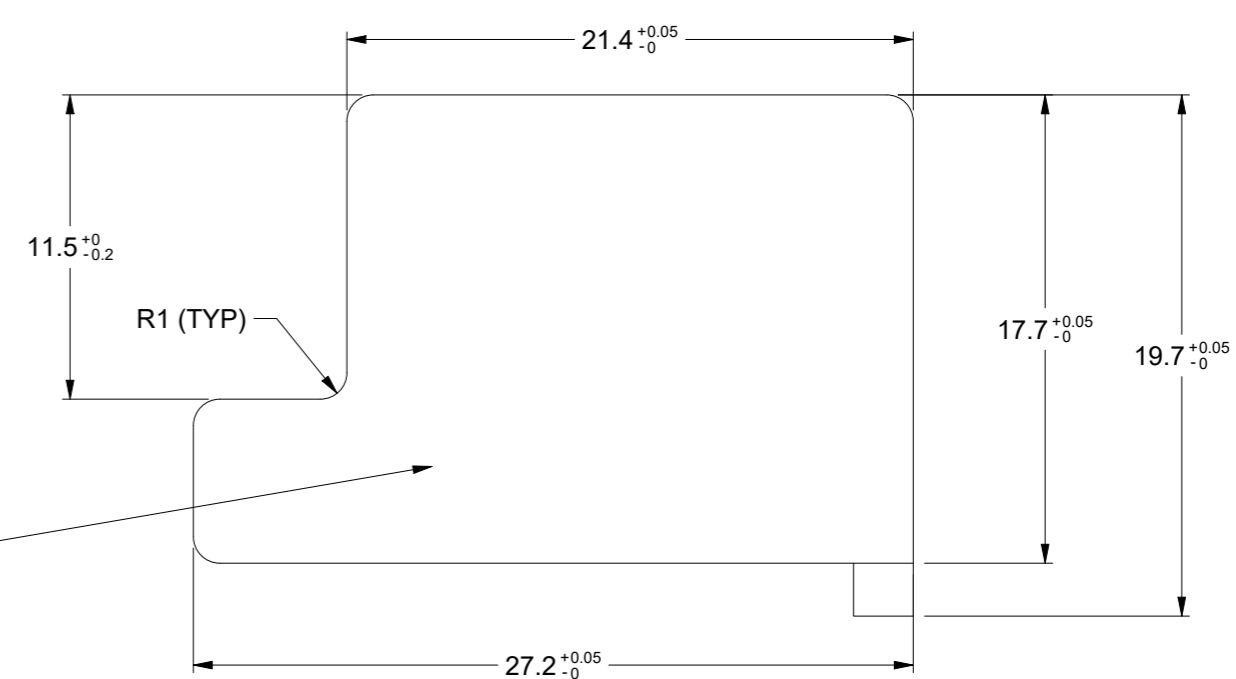

BOTTOM VIEW

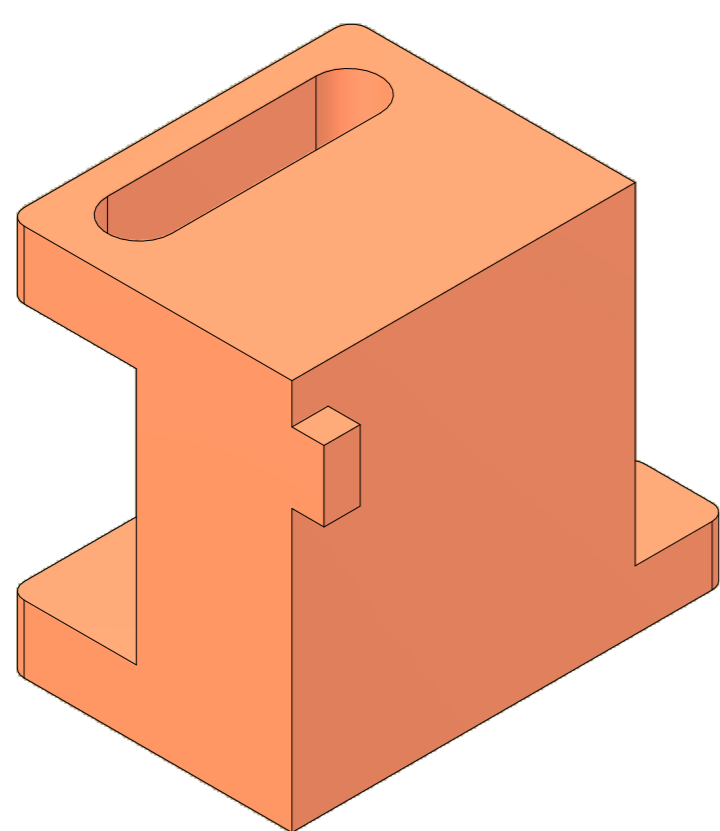

ISOMETRIC VIEW

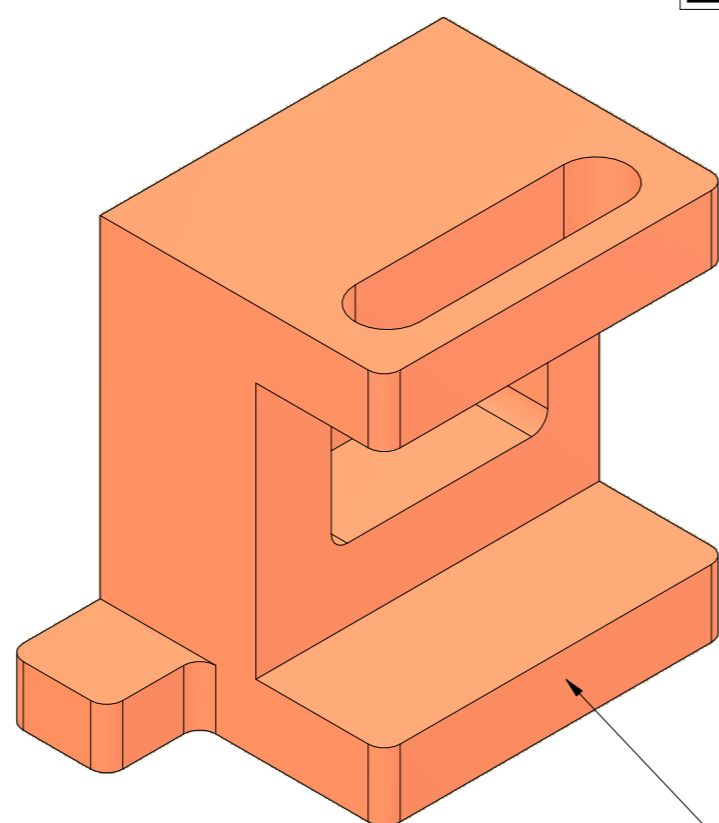

ISOMETRIC VIEW

NOTES:-

- 1) # JPC No. to be engraved for identification.
- 2) To be cleaned and de-burr properly.
- 3) Sharp corners to be avoided.
- 4) Surface finish requirement for all surfaces  $\nabla\nabla\nabla(\nabla\nabla)$ .

DEVIATION FOR NON TOLERENCED DIMENSIONS [ ISI : 2102 MEDIUM ]		1	BOTTOM BLOCK		31 X 24 X 29 THICK	AL6061 T6	-	REMARKS
DIAMETERS & LENGTHS UPTO & INCL.	LENGTH IN MM OF SHORTER SIDE OF ANGLE UPTO & INCL.	PART No.	DESCRIPTION	SIZE / REF.	MATERIAL	No. OFF	TOTAL REQD. WT. IN GMS.	
6	30 ± 0.2		DO NOT SCALE THE DRAWING UNLESS OTHERWISE STATED DIMENSIONS ARE IN MM REMOVE SHARP CORNERS					
30	120 ± 0.3		TITLE	TDP MIXER BOTTOM - PRE MICROMACHINING				
120	315 ± 0.5		DGN.	AAYUSH	GOVERNMENT OF INDIA DEPARTMENT OF SPACE			PROJECT TDP
315	1000 ± 0.8		DRN.	PRAVIN	31/05/24	SPACE APPLICATIONS CENTRE		
1000	2000 ± 1.2		DRG. CHD	ASHISH	AHMEDABAD-15			
2000	4000 ± 2.0		APD.	UBD	SCALE	DRG. NO.		SHEET 01
4000 & ABOVE	± 3.0		A2	SIGN	NTS	MMDD-TDP-230MIX-AL-PMB-01		OF 01
MACHINING FINISH IN MICRONS								
$\nabla$	8 - 25							
$\nabla\nabla$	0.025 - 1.6							
$\nabla\nabla\nabla$	1.6 - 8							
$\nabla\nabla\nabla\nabla$	< 0.025							