

Tender Preamble

LPSC(B) is in the process of establishing an Integrated Titanium Alloy Propellant Tank Production Facility (ITPF) at Tumakuru, Near Bengaluru (70 Km from Bengaluru) to gear-up augmented production of propulsion systems for increased satellite projects. The purpose of this facility is end to end realization of satellite propellant tanks and its subsystem on Government Owned and Company Operated (GOCO) model. As a part of the facility build-up at ITPF, a new Vibration test facility to cater to the vibration testing of propellant tanks and its subsystems.

The proposed facility consists of two numbers of 20 tonne Electrodynamic Shaker assembled in dual shaker mode by connecting to a common Slip Table in horizontal axis and to a Common Head Expander in vertical axis. The two shakers are synchronized for identical performance by a Dual Shaker Control Interface System (DSCIS). The dual shaker system will be used for conducting Sine vibration and Random vibration tests on propellant tanks and its subsystem. Vendor has to supply, install and commission the Vibration Test Facility (VTF) on turnkey basis as per the specifications detailed in the following sections.

Offers are invited from reputed suppliers, having experience and heritage in supplying the following

1. Electro Dynamic Shaker 2 Nos
2. Power amplifier with suitable capacity 2 Nos
3. Slip table 1 No
4. Head Expander for dual mode operation 1 No.
5. Dedicated Hydraulic power supply units: 3 Nos
6. Digital vibration Control system.
7. Digital vibration data acquisition system
8. Accelerometers, Signal conditioners and accessories.

This procurement is on a Two-Part Tender basis, PART-I is of Techno Commercial Bid and PART-II is of PRICE BID. After opening of PART-I (Techno Commercial Bid), Department will issue End User Certificate to the short-listed vendors. Vender has to obtain Export License within two months after receipt of End User Certificate, failing which the quotation/offer will not be considered.

Annexure – 1

- **System Technical Specifications**
- **Installation and Training**
- **Terms and Conditions**
- **Scope of Work and Supply**

I. TECHNICAL SPECIFICATIONS

Electrodynamic Shaker System

1. Introduction

- 1.1 Electro-dynamic Shaker is required to be used for carrying out Vibration testing of Propellant Tanks and its subsystem for satellite. The system should consist of 20 Ton Shaker system (2 Nos), Power amplifier (2 Nos), DSCIS (1 no), Slip Table (1 No) and Head Expander (1 Nos). In dual mode operation, both the shakers should be coupled to the slip table in push-push mode. Adequate test article Interfacing, static load capacity and dynamic force and moment capabilities shall be built into the system for the purpose as detailed in the specification. The system will be housed in a clean environment and hence sufficient care should be taken to ensure that the shaker system does not produce contaminants.
- 1.2 Vendor shall provide a techno-commercial presentation at LPSC, Bengaluru after as a part of technical evaluation of offers. The technical presentation shall include the following.
 - 1.2.1 Compliance matrix for the quoted system.
 - 1.2.2 Heritage for the quoted system.
 - 1.2.3 Technical schematic and details of the quoted system.
 - 1.2.4 Test results/data of the quoted system.

Vendors who have submitted their offers and not attending the techno-commercial presentation within 15 days of intimation from LPSC, Bangalore will not be considered.
- 1.3 Supplier should manufacture, supply, deliver to the site, install, commission the shaker system and provide test results as per the acceptance test plan. The major subsystems of the Shaker system shall comprise of
 - 1.3.1. Electrodynamic shaker with slip table.
 - 1.3.2. Externally Guided Head Expander for dual mode operation
 - 1.3.3. Dual Shaker Control Interface System (DSCIS)
 - 1.3.4. Digital switching power amplifiers with Matching Transformers
 - 1.3.5. Field Power Supply & Cooling/Chiller Units.

2.0	Specific requirement
2.1.	<p>Supplier's experience</p> <p>The supplier should have experience in supplying Electrodynamic shakers of 20,000kgf force capacity or higher capacity for Dual Mode Operation to Aerospace industries or Institutions</p>
2.2.	<p>Heritage of the offered system</p> <p>The supplier should have supplied at least one number of dual mode shaker system in the preceding 5 years with same configuration as detailed in the specifications to the aerospace industries or institutions. Test results and performance plots of such systems are to be provided. The supplied shaker system should have completed at least 12 months of satisfactory performance.</p> <p>The supplier should provide the details of dual mode shaker system supplied with contract / purchase order copies, model number, year of supply and copy of installation /acceptance report along with the details of the such customers including name of the organization, end user division/group and contact details of the end user.</p> <p>It should be noted that this will be one of the criteria for evaluation of the offer for technical suitability. The offers without this information will be rejected without any further reference.</p>
2.3.	<p>Local service support</p> <p>Supplier should have service center or authorized service center with trained service engineers in India. Service center address contact person details, phone/fax numbers, email should be provided along with the offer.</p>
2.4.	<p>Original manufacturer</p> <p>The quote should be only from the original manufacturer of the system. Incase if the offer is from the authorized representative, authorization certificate from the original manufacturer should be provided along with the quote.</p>
2.5.	<p>Certificate of origin</p> <p>Certificate of origin should include the following,</p> <ol style="list-style-type: none"> 1. Year of manufacturing 2. Country of manufacturing

3. SHAKER SYSTEM

Specification for single Shaker		
3.1.	General features	Common base type: Shaker trunnion and guiding system and slip table, mounted on a common steel structure providing permanent alignment with shaker and slip table. Configuration: Bolt down to foundation base plate Air isolation using air bellows Common base with lateral restraint mounts.
3.2.	Quantity	2 Nos
3.3.	Type	Water cooled
3.4.	Sine Force Rating (Peak)	$\geq 20,000$ Kgf
3.5.	Random Force Rating (Rms)	$\geq 17,000$ Kgf
3.6.	Maximum Half sine bump force	$\geq 40,000$ Kgf
3.7.	Static Load capacity	≥ 1200 Kg on bare table
3.8.	Useful frequency range	5 Hz to 2000Hz
3.9.	Body resonance frequency	≤ 3 Hz
3.10.	Max. Acceleration Sine Random Half Sine Shock	≥ 75 g pk (bare table) ≥ 55 g rms (20-100Hz: 6dB/Oct; 100-2000Hz: Flat PSD) ≥ 50 g peak, 10 ms
3.11.	Max. Velocity	≥ 1.8 m/sec for sine
3.12.	Max. Displacement	≥ 50.8 mm (2") Peak- Peak
3.13.	Axial stiffness	< 100 N/mm
3.14.	Cross axial Stiffness	$\geq 24,000$ N/mm
3.15.	Rotational Stiffness	≥ 500 KN m/rad
3.16.	Offset Moment	≥ 2.8 KNm
3.17.	Minimum possible test level	3.17.1. ≤ 0.2 g peak swept sine test from 5 Hz to 2000 Hz in Broad Band RMS (BBRMS) measurement mode with (12.8 kHz) bandwidth for control channel.

		<p>3.17.2. Control location on armature top</p> <p>3.17.3. With power amplifier 100% gain</p>
3.18.	Armature Diameter	≤ 760 mm Nominal
3.19.	Armature mass	≤ 250 kg
3.20.	Fundamental Armature Resonance	≥ 1250 Hz
3.21.	Armature Cross axis	<p>Excluding Resonance Peaks: 5 Hz – 500 Hz: < 12%; 500 Hz – 1000 Hz: < 15%;</p> <p>Including resonance Peaks: 5 Hz – 100 Hz: < 12%; 100 Hz – 200 Hz: < 35%; 200 Hz – 1000 Hz: < 50%; 1000 Hz – 2000 Hz: < 80%;</p> <p>Measured on higher PCD of the armature without load.</p>
3.22.	Armature Suspension	Armature shall be supported with suitable suspension mechanisms such as flexures, rolling strut assemblies, etc. The necessary drawings shall be provided.
3.23.	Armature guidance	Armature shall be internally guided with suitable Hydrostatic journal bearings to provide lateral movement restraint.
3.24.	Armature over travel interlock	Armature over travel should be sensed using non-contact type optical sensor/scale. Armature over travel interlock should trip the power amplifier.
3.25.	Armature position display	<p>3.25.1. Armature position should be sensed using non-contact type optical sensor/scale</p> <p>3.24.1. Digital or LED bar graph display of the armature position should be provided simultaneously near the shaker as well as at the remote-control panel at control room approximately 50 meters away from shaker bay.</p>
3.26.	Shaker body position display	<p>3.26.1. Shaker body position should be sensed using non-contact type optical sensor/scale</p> <p>3.26.2. Digital or LED bar graph display of the armature position should be provided simultaneously near the shaker as well as at the remote control panel at control room approximately 50 meters away from shaker bay.</p>

3.27.	<p>Raised inserts for armature table (Typical)</p>	<p>These interface holes should be provided with UNC-M12 stainless steel inserts.</p> <p>3.26.1 One number of M12 insert at center (if feasible)</p> <p>3.26.2 8 numbers of M12 inserts at 8” PCD</p> <p>3.26.3 8 numbers of M12 inserts at 16” PCD</p> <p>3.26.4 8 numbers of M12 inserts at 22” PCD</p> <p>3.26.5 8 numbers of M12 inserts at 28” PCD (only if armature diameter \geq 750 mm)</p>
3.28.	<p>Auto centering of armature</p>	<p>3.28.1. Auto-centering of the armature for the rated static load should be provided. This should be achieved with non-contact type optical sensing and pneumatic servo based armature position control system.</p> <p>3.28.2. Manual over ride provision should also be provided.</p> <p>3.28.3. Display of armature position monitoring shall be provided.</p>
3.29.	<p>Adaptor plate– 1(1 no.)</p> <p>3.29.1. Flatness:\leq 0.1mm per meter</p> <p>3.29.2. Surface finish: 3-triangle finish or better (roughness average \leq 1.6micron)</p> <p>3.29.3. Parallelism: 0.2mm per meter or better</p>	<p>50 mm thick magnesium alloy (AZ31) circular plate with following specimen interface and suitable with armature table insert pattern of Sl.No.3.26. Inserts are UNC-M12 / M8 stainless steel inserts flushed with plate surface.</p> <p>a. One hole at center – M12 Insert</p> <p>(Applicable only if the armature table does not have insert at center)</p> <p>b. 6” PCD with 8 Holes at 45° – M8 inserts</p> <p>c. 8” PCD with 8 Holes at 45° – M12 inserts</p> <p>d. 12” PCD with 8 Holes at 45° – M8 inserts</p> <p>e. 16” PCD with 8 Holes at 45° – M12 inserts</p> <p>f. 22” PCD with 8 Holes at 45° – M12 inserts</p> <p>g. 28” PCD with 8 Holes at 45° –M12inserts (only for armature diameter of >750 mm)</p>
3.30.	<p>Armature mechanical locking and interlock</p>	<p>3.30.1. Mechanical locking of armature with shaker body when the shaker is in idle condition to be provided.</p> <p>3.30.2. Mechanical locks should have interlock with power amplifier.</p>
3.31.	<p>Armature Lock-out Mechanism with interlock</p>	<p>a) Provision to mechanically lock-out the Armature when not in operation shall be provided to support the entire moving mass including the Static load around 1200kg.</p>

		<p>b) Interlock Switches for the locking mechanism shall be provided.</p> <p>c) Interlock shall be provided with Cooling Unit/Power Amplifier.</p>
3.32.	Geared shaker rotation	<p>3.32.1. Rotating mechanism with reduction gear for assembling the shaker to the slip table</p> <p>3.32.2. Electrical cables, water hoses and Hydraulic hoses are to be properly guided and secured during shaker rotation.</p>
3.33.	Shaker body suspension	Shaker body suspended with respect to trunnion should have locking provision in vertical and horizontal position.
3.34.	Shaker vertical / horizontal tilt switch	Shaker vertical / horizontal tilt switch interlocked with slip table hydraulic supply and power amplifier should be provided.
3.35.	Trunnion guidance	<p>The shaker unit should be provided with a trunnion and guidance system with Pneumatic isolation system.</p> <ul style="list-style-type: none"> • The vibrator shall be trunnion mounted, which allows the thrust axis to be rotated from the vertical to the horizontal by means of a motor or manual drive coupled to a gearbox; • The vibrator body shall be provided with guidance system. • The vibrator body should be isolated from the ground by means of air mounts of appropriate capacity;

3.36.	Shaker Cooling unit.	<p>3.36.1. The shaker should be provided with an external de-ionized /distilled water-based cooling unit which in-turn is cooled by raw water.</p> <p>3.36.2. The cooling unit shall be of suitable capacity for cooling of the shaker system. Rating and technical details of the cooling system shall be provided along with technical quote.</p> <p>3.36.3. Cooling unit shall incorporate digital display of Armature inlet temperature, Armature outlet temperature and Field Coil temperatures.</p> <p>3.36.4. The cooling unit should incorporate interlocks for raw water temperature, raw water flow, armature coil temperature, field coil temperature, shaker body temperature, etc.</p> <p>Note: Chiller unit of suitable capacity to be provided.</p>
3.37.	Liquid detection sensor for shaker body	Shaker body should be fitted with a Liquid detection sensor to detect any internal leaks form armature coils, and field coils and hydro static bearings.
3.38.	Scavenging pump for shaker hydraulic oil.	<p>3.38.1. Hydraulic oil return line should be fitted with a scavenging pump of appropriate capacity.</p> <p>3.38.2. Shaker combo base to be installed below the floor level based on site condition.</p>
3.39.	Hydraulic power supply unit	<p>3.39.1. A suitable Hydraulic power supply unit with oil pressure interlock, required oil hoses and electrical cables are to be provided, for a length of 30 m minimum.</p> <p>3.39.2. Electrical Mains Supply: 3 phase, 415V AC +/- 5%,50 Hz.</p>
3.40.	Operating Environment	<p>3.40.1. Temperature: 15°C to 35°C</p> <p>3.40.2. Relative Humidity: 20% to 80%</p>
3.41.	Shaker Handling provision for movement through Crane	<p>3.41.1. Provision shall be provided for mounting of eye-bolts of suitable diameter for movement of the shaker using overhead crane.</p> <p>3.41.2. Accessories for handling, lifting and movement like, suitable handling Eyebolts, etc., shall be also be supplied.</p>
4.	Slip-Table	

4.1.	<p>4.1.1. Shaker system with trunnion support and slip-table should be mounted on to a common Steel structure (seismic base structure with steel base plate) in a suitable manner for providing permanent alignment of Shaker with the Slip table.</p> <p>4.1.2. The shaker and slip table shall be designed to support detaching of the Shaker system and slip table whenever required.</p> <p>4.1.3. The Slip Table should have appropriate mounting interface for connecting the two numbers of shaker system for Twin shaker operation in push-push mode.</p> <p>4.1.4. The shaker unit along with Slip Table should be isolated from floor using Air mounts of appropriate capacity, to ensure that the vibration at full load is not transmitted to the floor.</p> <p>4.1.5. The provision shall exist to by-pass and bolt-down the Air mount of the shaker/Slip table directly to the seismic foundation using the steel base plates.</p> <p>4.1.6. The common base shall be provided with Lateral restraint mounts.</p> <p>4.1.7. Slip plate shall be supported by granite base with oil film and guided by high pressure hydrostatic journal bearings.</p> <p>4.1.8. The maximum number of bearings required to be populated around the centre to get the specified moments (ref. spec. 4.7) and to minimize cross-axis response (ref. spec. 4.10).</p> <p>4.1.9. Supplier shall submit the fabrication drawing of the slip plate for LPSC, Bengaluru approval with respect to bearing configuration and insert pattern before proceeding with fabrication.</p>	
4.2	Slip Table dimension	2500mm (L) X2500 (W) X 70mm (T)
4.3	Slip plate material	Magnesium Alloy (AZ31) Tool plate
4.4	Flatness:	≤ 0.1mm per meter
4.5	Surface finish:	3-triangle finish or better (Roughness average ≤ 1.6micron)
4.6	Parallelism:	0.2 mm per meter or better

4.7	Overturning Moment (Supplier to provide the bearing configuration as part of technical offer)	4.7.1 Pitch	>650 kN-m
		4.7.2 Roll	>700 kN-m
		4.7.3 Yaw	>150 kN-m
4.8	Number of high-pressure hydrostatic journal bearings (Supplier to provide the bearing configuration as part of technical offer)	4.8.1 26 Nos. minimum 4.8.2 Complete dimensional and performance details for the different type of bearings used shall be provided as part of technical offer. 4.8.3 Optimum bearing configuration to meet the moment capability as per Sl. No. 4.7 and cross axis response as per Sl. No. 4.10 to be provided. In case of the proposed bearing configuration requires installation of less number of bearings, the remaining bearings are to be supplied as spares. 4.8.4 The Final bearing configuration will be approved by LPSC (B) at the time of order.	
4.9	Bare table resonance frequency	>500 Hz	
4.10	Cross axis responses	Excluding Resonance Peaks: 5 Hz – 500 Hz: < 12%; 500 Hz – 1000 Hz: < 15%; Including resonance Peaks: 5 Hz – 100 Hz: < 12%; 100 Hz – 200 Hz: < 35%; 200 Hz – 1000 Hz: < 50%; 1000 Hz – 2000 Hz: < 80%; Measured on higher PCD of the slip-table without load as per FAT measurement plan.	
4.11	Maximum static payload capacity	≥ 22,000 kg	
4.12	Displacement	≥ 40 mm peak to peak (bare table)	
4.13	Combined Useful Frequency range of shaker with slip-table	5 to 2000 Hz.	
4.14	Mounting hole pattern	4.14.1) 100 mm X 100 mm grid – M12 inserts 4.14.2) 900 mm PCD – 16 holes– M12 inserts 4.14.3) 1200 mm PCD – 32 holes–M12 inserts 4.14.4) 1700 mm PCD - 96 Holes – M12 inserts 4.14.5) 2100 mm PCD - 96 Holes – M12 inserts	

		<p>All Inserts are UNC-M12 stainless steel inserts flushed with slip-plate surface.</p> <p>Inserts should have locking pins apart from self locking inserts.</p> <p>The bearing mounting holes shall be optimised to avoid interference with any PCD/Grid insert pattern as far as possible.</p> <p>In case of interference of 100mm × 100mm grid inserts with PCD inserts or bearing holes, the interfering grid inserts can be deleted to accommodate the PCD inserts or bearing holes.</p>
4.15	Accelerometer mounting	10-32 UNF heli-coil at an interval of 0.5mtrs at from slip table centre. (multiple points)
4.16	Driver bar	<p>4.16.1 Type: Tension bolt type</p> <p>4.16.2 All welded construction.</p> <p>4.16.3 Material: Magnesium Alloy (AZ31)</p> <p>4.16.4 Handling provision for lifting/mounting/movement (eyebolt handling provision)</p>
4.17	Hydraulic power supply unit	<p>4.17.1 A suitable Hydraulic power supply unit with oil pressure interlock, required oil hoses and electrical cables are to be provided.</p> <p>4.17.2 Electrical Mains Supply: 3 phase, 415V AC +5%, 50 Hz.</p> <p>4.17.3 Scavenging pump of appropriate capacity to be provided.</p> <p>4.17.4 Shaker combo base to be installed below the floor level based on site condition.</p>
4.18	Slip plate over travel switch	Slip plate over travel switch to be interlocked to power amplifier
4.19	Slip plate surface temperature	Maximum stabilized slip plate temperature should not exceed 45°C under the laboratory ambient of 25°C.
4.20	Operating Environment	<p>4.20.1 Temperature: 15°C to 35°C</p> <p>4.20.2 Relative Humidity: 20% to 80%</p>
5	Externally Guided Head Expander	
5.1	Type	5.1.1 Externally Guided head Expander.

		<p>5.1.2 Guided Head Expander should be designed such that it couples both Shakers in vertical configuration for dual mode operation.</p> <p>5.1.3 Cross section schematic diagram to be provided showing the details of external guidance and construction details.</p> <p>5.1.4 Suitable flexure to be provided with tuned mass dampers.</p>
5.2	Table Diameter (Typical)	2500 mm
5.3	Moving mass (Typical)	<1500 kg (excluding armature)
5.4	Moving element material	Magnesium alloy
5.5	Flatness:	≤ 0.1 mm per meter
5.6	Surface finish:	3-triangle finish or better (roughness average ≤ 1.6 micron)
5.7	Locking Mechanism with interlock	<p>5.7.1 Provision to mechanically lock the moving element when not in operation.</p> <p>5.7.2 Interlock switches for locking mechanism.</p> <p>5.7.3 Interlocked with power amplifier/ cooling unit</p>
5.8	Displacement	≥ 40 mm Peak to Peak (bare table)
5.9	Hydraulic power supply	<p>5.9.1 A dedicated suitable Hydraulic power supply unit with oil pressure interlock, required oil hoses and electrical cables are to be provided.</p> <p>5.9.2 Electrical Mains Supply: 3 phase, 415V AC +5%, 50 Hz.</p> <p>5.9.3 Scavenging pump of appropriate capacity to be provided.</p>
5.10	Bare table resonance frequency	≥ 250 Hz
5.11	Static Load Capacity	≥ 10000 Kg
5.12	Mounting hole pattern	<p>5.12.1 100mm \times 100mm grid – M12 inserts</p> <p>5.12.2 900mm PCD – 16 holes- M12 inserts</p> <p>5.12.3 1200 mm PCD–32 holes -M12 inserts</p> <p>5.12.4 1700 mm PCD- 96 Holes–M12 inserts</p> <p>5.12.5 2100 mm PCD - 96 Holes – M12 inserts</p>

		<p>All Inserts are UNC-M12 stainless steel inserts flushed with slip-plate surface.</p> <p>Inserts should have locking pins apart from self-locking inserts.</p> <p>The bearing mounting holes shall be optimised to avoid interference with any PCD/Grid insert pattern as far as possible.</p> <p>In case of interference of 100mm × 100mm grid inserts with PCD inserts or bearing holes, the interfering grid inserts can be deleted to accommodate the PCD inserts or bearing holes.</p>
5.13	Operating Environment	<p>5.13.1 Temperature: 15°C to 35°C</p> <p>5.13.2 Relative Humidity: 20% to 80%</p>
6	Power Amplifier 2 Nos (1 no for each shaker)	
6.1	Type	<p>6.1.1 Pulse Width Modulated (PWM) switching type, Class-D amplifier (Digitally modulated power amplifier).</p> <p>6.1.2 Modular in construction</p> <p>6.1.3 Scalable architecture.</p> <p>6.1.4 Provision to separately supply power to armature during head expander mounting is preferred.</p>
6.2	Amplifier Capacity	<p>Total capacity shall be suitable to the rated capacity of the shaker.</p> <p>Number of power modules required for rated capacity to be provided.</p>
6.3	Individual power module capacity	<p>6.3.1 $\geq 5\text{kVA}$ and should not be more than 15kVA</p> <p>Specify Maximum sine current rating and Maximum voltage rating.</p>
6.4	Frequency Response	<p>Full power: 10Hz to 2000 Hz</p> <p>Half power (-3dB): 3 kHz</p>
6.5	Efficiency	$\geq 90\%$
6.6	Switching Frequency	$\geq 100\text{ kHz}$
6.7	Total Harmonic Distortion (THD) when connected with shaker	<p>With an acceleration of 1 g on armature bare table top between 5 Hz to 100 Hz and with 2 kHz measurement bandwidth, the THD should be $\leq 5\%$.</p> <p>THD shall be computed as per ISO 5344 standard.</p>

6.8	Hum and Noise of amplifier output	≤ 0.05 V rms. With input shorted and maximum gain.
6.9	Peak current handling	Approximately three times or more than the continuous sine current rating for a period of 100 ms
6.10	Soft Start and Stop	Soft Start and Stop to avoid transients due to switching ON and OFF of the amplifier
6.11	Connections provision	Heavy- duty terminal blocks for connecting vibrator armature cables.
6.12	Cable length between amplifier and shaker	30 meters typical for meeting the 100% force rating of the shaker system. (Final length will be given at the time of ordering)
6.13	Line Filter (Power)	Line filter (RFI filter) to be incorporated to meet the emission levels specified by European Union (EU) directive 2004/108/CE (previously 89/336/EEC) or equivalent standard. The total system should comply with EU directive 2004/108/CE or equivalent standard.
6.14	Signal Inputs	6.14.1 1 Vrms for 100Vrms output. 6.14.2 Differential input compatible with Standard Vibration Controllers
6.15	Output Voltage	Should be compatible with the Shaker
6.16	Input Impedance	$\geq 10k\Omega$
6.17	Power amplifier acoustic noise level	≤ 90 dBA at 1 m distance
6.18	Power module protection for power blackout	The power devices / modules should be protected from failure during abrupt mains power blackout during operation.
6.19	Electrical Mains Supply	3 Phase, 415 Volts AC $\pm 5\%$ 50 Hz { Tapping on input of transformer required: 380V, 400V, 415V, 440V, 460V }
6.20	Control and Protection Circuits	Microprocessor based system

- 6.21 Controls to be provided
ON/OFF controls from amplifier local and remote panels for the following:
 - 6.21.1 Field power supply
 - 6.21.2 Cooling unit
 - 6.21.3 Hydraulic oil supply unit
 - 6.21.4 Amplifier Gain
- 6.22 Interlocks to be provided (Typical)
 - 6.22.1 Shaker over travel
 - 6.22.2 Armature coil over temperature
 - 6.22.3 Field coil over temperature
 - 6.22.4 Shaker vertical/Horizontal interlock
 - 6.22.5 Low voltage supplies fault
 - 6.22.6 HT Under voltage/Over voltage
 - 6.22.7 Module over current / Fault
 - 6.22.8 Power amplifier over load
 - 6.22.9 Field failure
 - 6.22.10 Cooling unit fault
 - 6.22.11 Slip table/Shaker Hydraulic oil pressure fault
 - 6.22.12 Slip Table over travel
 - 6.22.13 Emergency abort
 - 6.22.14 External trip
- 6.23 Monitoring outputs
 - 6.23.1 Scaled down output for armature voltage
 - 6.23.2 Scaled down output for armature current
- 6.24 Digital display of temperature in cooling unit
 - 6.24.1 Armature inlet temperature
 - 6.24.2 Armature outlet temperature
 - 6.24.3 Field coil inlet temperature
 - 6.24.4 Field coil outlet temperature
 - 6.24.5 Distilled / de-ionised water temperature in tank
- 6.25 Metering
 - 6.25.1 Amplifier output voltage
 - 6.25.2 Amplifier output current

6.26	<p>Indications</p> <p>Amplifier Interlocks and status display at local and remote panels</p> <p>6.26.1 Auxiliary power supplies ON</p> <p>6.26.2 Mains supply Low/ High voltage</p> <p>6.26.3 Low voltage supplies fault</p> <p>6.26.4 HT Under voltage/Over voltage</p> <p>6.26.5 Output over current</p> <p>6.26.6 Output over voltage</p> <p>6.26.7 Vibrator cooling fault</p> <p>6.26.8 Vibrator over travel</p> <p>6.26.9 Field failure</p>	
6.27	<p>Remote Control Panel (50 m distance from amplifier)</p> <p>6.27.1 Auxiliary ON/OFF control</p> <p>6.27.2 Amplifier ON/OFF control</p> <p>6.27.3 Gain control</p> <p>6.27.4 All Indications</p> <p>6.27.5 Metering display of output voltage</p> <p>6.27.6 Metering display of output current</p> <p>Note: In case of software based remote control panel, suitable software and required hardware (PC) to be provided.</p>	
6.28	Overload settings	Provision at front panel or remote unit for limit setting of amplifier output current and output voltage.
6.29	Cooling	Forced air cooled
6.30	Construction	<p>6.30.1 Construction should be such that physical addition or removal of power modules should be easily carried out and whole amplifier system should be mounted on integrated 19" racks with wheels and jacks</p> <p>6.30.2 Openings should be sealed to make it rodent free.</p> <p>6.30.3</p>
6.31	Operating environment	<p>6.31.1 Temperature: 15°C to 35°C</p> <p>6.31.2 Relative Humidity: 20% to 80%</p>
6.32	Run time meter	
7	Dual Shaker Control Interface System (DSCIS) – 1 No.	

7.1	Dual shaker shall be operated in PUSH-PUSH configuration	
7.2	Shakers should be configured in such a way that single mode operation shall be enabled as and when required.	
7.3	Necessary safety interlocks for specimen protection shall be incorporated.	
8	Field Power Supply (FPS) - 2 Nos.	
8.1	Type	Standalone or built-in with amplifier
8.2	Power Rating	Should be suitable to deliver the full rated load, with a provision to vary the output.
8.3	Economy mode and Full field mode	Automatic change over for 8.3.1 Reduced field current when power amplifier is disabled 8.3.2 Full field when power amplifier is enabled
8.4	Stray Magnetic field	≤ 1.5 mT at 150mm above armature table
8.5	Field protection	The field power supply should be protected against short circuit and should be provided with freewheeling diodes.
8.6	Interlocks	Should be provided with suitable interlock with amplifier for auto start and field failure indication.
8.7	Electrical Mains Supply	3 Phase, 415 Volts AC ± 5% 50 Hz {Tapping on input of transformer required: 380V, 400V, 415V, 440V, 460V}
8.8	Line Filter (Power)	Line filter (RFI filter) to be incorporated to meet the emission levels specified by European Union (EU) directive 2004/108/CE (previously 89/336/EEC) or equivalent standard. The system should comply with EU directive 2004/108/CE or equivalent standard.
8.9	Metering (Digital)	8.9.1 Field current 8.9.2 Field voltage
8.10	Cable length between FPS and shaker	30 meters typical. (Final length will be given at the time of ordering)
8.11	Cooling	Forced air cooled
8.12	Construction	8.12.1 Standard 19" racks with wheels and jacks.

		8.12.2 Openings should be sealed to make it rodent free.
8.13	Operating environment	8.13.1 Temperature: 15°C to 35°C 8.13.2 Relative Humidity: 20% to 80%
9	Other requirements	
9.1	Emergency abort switches	Emergency abort switches at shaker, FPS, Power amplifier, slip-table and at Remote control panel
9.2	Cables between Shaker Amplifier	Connecting Copper cable length between Filed power supply and Amplifier to the shaker is typically 30 meters (Final length will be given at the time of ordering)
9.3	Quality of Finish	All equipment's should have good finish with anti-corrosive protection
9.4	Duty Cycle	The Shaker/Amplifier/Slip Table/ Guided Head Expander should be rated for One-hour continuous operation at full rated output force.
9.5	Alignment and maintenance tool kit	Tool kit comprising of the necessary tools is to be supplied for alignment and maintenance of the shaker system Detailed list of tools of the tool kit should be given.
9.6	List of deliverables	List of deliverables to meet the functional requirements should be given along with the Techno commercial quote (Part-I of the offer).
9.7	Utility requirements Supplier should provide details of the utilities required for operation of the shaker system like power requirements, water flow and pressure requirements, compressed air requirements, etc.	

II. TECHNICAL SPECIFICATIONS

Digital Vibration Control System

1.0 Digital Vibration Control System

Sl. No.	Features	Range/value
1.1	Introduction	
	The 24 channel Digital Vibration Control System (with provision for future expansion up to 64 channels) should be capable of operating dual shaker system in PUSH-PUSH configuration for carrying out sine, random and shock testing of satellite propellant tanks and subsystems.	
1.2	Digital vibration control system should be any one of the following make and model which were qualified by LPSC(B) / URSC	
	1.2.1 Abacus Signal Star- Vector from M/s Data Physics (or)	
	1.2.2 Scadas Lab from M/s Siemens PLM	
	1.2.3 M+p control system	
2.0	Hardware	
2.1	Instrumentation Front End	
2.1.1	Number of Input Channels	Minimum of 24 channels with provision for future expansion up to 64 channels
2.1.2	No of outputs	2.1.2.1 Minimum of four from independent Digital to Analog hardware
2.1.3	Input and output connectivity	2.1.3.1 BNC Connector. 2.1.3.2 If BNC connectors are provided on a breakout box, these breakout boxes should be mounted on a 19" rack panel for ensuring rigid support.
2.1.4	Calibration/validation	2.1.4.1 It should be possible to carry out ON-SITE Instrumentation front-end calibration without the need of support/intervention from the vendor. 2.1.4.2 Any H/W & S/W accessories for the same shall be provided as part of deliverables. 2.1.4.3 Offset removal and gain linearity check for all the input/output channels should be provided. 2.1.4.4 In case if any channel fails in calibration, the calibration process should continue skipping that particular channel. It should be possible to isolate/disable the failed channel in further calibration steps.

Sl. No.	Features	Range/value
2.2	COMPUTER	
	Vendor has to ensure that the computer platform chosen is sufficient to meet overall functional requirement of control system	
2.2.1	Operating System	Microsoft Windows-10 Professional 64-bit or better or Linux with support.
2.2.2	Platform	2.2.2.1 Intel i7-4790 3.6 GHz (8 cores) Processor or Better 2.2.2.2 Suitable high-speed system bus or better. 2.2.2.3 Intel/OEM Chipset on OEM motherboard compatible with quoted processor.
2.2.3	RAM	2.2.3.1 Minimum 32 GB DDR4 RAM or better. 2.2.3.2 System shall support memory extension up to 64 GB. 2.2.3.3 Minimum Two DIMM slots shall be free after configuring all the required memory modules. Specify total and occupied DIMM slots. 2.2.3.4 Vendor shall configure memory DIMM as per the best practices specified by processor OEM for the best and balanced performance.
2.2.4	Hard disk	2.2.4.1 1 set (2 numbers) of 2TB (min.) or better HDD with RAID 1 (disk mirroring) feature for OS & application software. 2.2.4.2 1 set (2 numbers) of 2TB (min.) or better HDD with RAID 1 (disk mirroring) feature for data storage. 2.2.4.3 The hard disk shall be with SATA interface; e-SATA/NL-SAS interfaces are preferred. 2.2.4.4 The hard disk shall be divided into two logical drives one for OS/application software and another for data.
2.2.5	Monitor	2.2.5.1 Two numbers of 28 inch or higher Size, full HD LED monitors with 1920 x 1080P resolution or better. 2.2.5.2 These monitors shall be connected in Dual Mode configuration. 2.2.5.3 Monitor shall be of Non-Touch type.
2.2.6	DVD-R/W Drive	16X or better DVD Super Multi double-layer drive with DVD and CD read-write capability.

Sl. No.	Features	Range/value
2.2.7	I/O ports	2.2.7.1 USB 3.0 or better – minimum 2 nos. 2.2.7.2 USB ports to connect mouse, Keyboard, Printer and Scanner shall be provided separately.
2.2.8	Pointing Device	2.2.8.1 USB Optical Scroll mouse.
2.2.9	Keyboard	2.2.9.1 Space saver ergonomic keyboard with 104 keys or better.
2.2.10	Networking	2.2.10.1 Minimum 1Gbps Ethernet LAN port to connect to Instrumentation front end. 2.2.10.2 One Additional 1Gbps Ethernet LAN port to connect computer to LAN network. 2.2.10.3 The network port shall be RJ45 connector.
2.2.11	Additional Display Port	2.2.11.1 1 No. , Apart from connecting the computer to display monitors, shall have provision to simultaneously connect the computer to standard high resolution external LED display or external projector.
2.2.12	Graphics	2.2.12.1 Integrated dual graphics supporting FHD resolution. Video interface: Display Port, HDMI 2.2.12.2 Graphics card shall support simultaneously three displays in the following configuration <ul style="list-style-type: none"> ○ 2 monitors in Dual Mode configuration. ○ 1 for external projector or high resolution external LED display with HDMI interfaces to display the content of one of the dual monitors.
2.2.13	Display Projection	2.2.13.1 The system shall be able to interface to the projector system or on LED display of the master screen with master/slave monitors enabled for viewing. 2.2.13.2 The vendor shall clearly bring out any issues in interfacing the control system to the projector or LED display. 2.2.13.3 Quote shall be given separately if any additional hardware required for connecting the projector or LED display. 2.2.13.4 The required accessories to connect different type of projector shall be provided.

Sl. No.	Features	Range/value
2.2.14	Licensing and recovery of OS	2.2.14.1 The OS shall be licensed with license key. OS Recovery and Driver DVD to be supplied.
2.2.15	Additional network switch	2.2.15.1 One 16/24 port 1Gbps unmanaged network switch shall be mounted in the rack provided with the quoted system.
2.2.16	Removable Hard disk	2.2.16.1 2 nos. of 2TB removable HDD with USB interface for data portability.
2.2.17	Printer and scanner	<p>Color Printer</p> <p>2.2.17.1 1 No. of Color Laser jet Printer with scan function, built-in USB & network port, with automatic duplex (double side) printing capability, Paper size: A4, printing speed of minimum of 30 PPM and resolution of minimum of 600 dpi.</p> <p>2.2.17.2 The printers shall be of latest model, supplied with Indian warranty and shall be locally serviceable.</p>
2.2.18	ELECTRICAL SUPPLY	
2.2.18.1	Voltage	All equipment should support for 220 Volts AC
2.2.18.2	Frequency	50 Hz \pm 5%
2.2.18.3	Phase	Single
2.2.19	OPERATING ENVIRONMENT	
2.2.19.1	Operating temperature	15°C to 35°C
2.2.19.2	Relative Humidity	20% to 80%

3.0	SOFTWARE	
3.1	General Provisions	
3.1.1	<ul style="list-style-type: none"> • Software features listed in this section of 3.1 should be provided to all the software modules defined in sections 3.2, 3.3, and 3.4 • The software should cater for Control, Acquisition and Analysis for Swept Sine, Dwell, Resonance Dwell, Random, Classical Shock and SRS testing of Spacecraft Propellant Tank and its subsystems using Electro-Dynamic Shakers. • Transient Data reproduction of previously recorded signal or signal generated using in-built software on Shaker shall also be provided. 	
3.1.2	Channels Setup Parameters	3.1.2.1 Sensitivity definable in terms of mV/EU 3.1.2.2 Channel Naming 3.1.2.3 Input coupling – AC, DC, IEPE 3.1.2.4 Option to include/exclude individual channels in loop check 3.1.2.5 Option to activate/inactivate automatic nulling of the offset before test beginning should be provided 3.1.2.6 Option to set a channel as control/measurement channel. 3.1.2.7 Importing of channel definition file between sine, random, shock, and SRS test definitions 3.1.2.8 Storing channel setup data in file for future recall. 3.1.2.9 Printing channel setup values.
3.1.3	Data display options	3.1.3.1 Tiled display with data displayed one next to the other. 3.1.3.2 Data of multiple channels of single and multiple tests should be displayable in single and multiple windows, with up to 4 channels per window and up to 4 windows displayable at a time to enable comparison between two test data. 3.1.3.3 Over-plotting of the selected channels preferably between different tests. 3.1.3.4 Over-plotting of all the channels between different tests. 3.1.3.5 Hard copy printing provision for all the above display plots.

3.1.4	Cursor Operations	<p>3.1.4.1 Provision to list selected points of the graph along with the graph</p> <p>3.1.4.2 Zooming of a selected band in the graph should be possible.</p> <p>3.1.4.3 Automatic peak picking in the selected range of frequency and amplitude. Provision for manual peak picking to add additional peaks along with automatically picked peaks.</p> <p>3.1.4.4 Manual & Automatic setting of the range for X and Y-axes.</p> <p>3.1.4.5 Option to set Linear/logarithmic scale for X and Y-axes.</p> <p>3.1.4.6 Option to enable/disable grid lines.</p>
3.1.5	Batch Printing	<p>3.1.5.1 Batch printing of selected channels with automatic peak picking in selected range of frequency and amplitude</p>
3.1.6	Report Generation	<p>3.1.6.1 Facility should be present to save the display plots in PDF format as well as Microsoft word or equivalent format for report generation purpose.</p> <p>3.1.6.2 It should be possible to export all plots of a test at once to MS word or equivalent with optional peak picking for each of the plots.</p> <p>3.1.6.3 Necessary software required for the above should be supplied along with the system.</p>
3.1.7	Documentation and Data Storage	<p>3.1.7.1 Output Spectra of all channels, drive, reference, tolerance, and notching & abort limits.</p> <p>3.1.7.2 Provision for entering two lines of legend for each test.</p> <p>3.1.7.3 Message Log for each test</p>
3.1.8	Data exchange	<p>Import and export support for</p> <p>3.1.8.1 Universal File Format- data set 58/58B & other data sets</p> <p>3.1.8.2 Spread sheet format.</p> <p>3.1.8.3 ASCII data file and MATLAB - Export only.</p>
3.1.9	Control system dynamic range	Better than 90dB

3.1.10	Safety Features	<p>3.1.10.1 Loop check to detect input anomalies before test with following features</p> <ul style="list-style-type: none"> o User selectable maximum output drive voltage o User selectable noise threshold in mV RMS. o Measurement of loop gain, noise, etc., should be possible. <p>3.1.10.2 User selectable threshold for control signal loss.</p>
3.1.11	Control features during testing	<p>3.1.11.1 ABORT, Start and Resume functions.</p> <p>3.1.11.2 Start up from low level to full level in user defined level steps/time.</p> <p>3.1.11.3 Provision for Manual or Auto start selection from initial test level to full level.</p> <p>3.1.11.4 On line message/status display of test activities</p>
3.1.12	Security Features	<p>3.1.12.1 User Level Access Control</p> <p>3.1.12.2 Test data access control</p>
3.1.13	Instrumentation Front-end Calibration	<p>3.1.13.1 Provision for on-site Instrumentation Front-end Calibration should be provided with Calibration Software and associated Hardware/accessories for field calibration as per specification 2.1.17</p>
3.1.14	Time domain data display	<p>3.1.14.1 Provision should exist for time domain data display of all channels for the purpose of verification prior to start of test.</p>
3.1.15	Post test data review	<p>3.1.15.1 Data review of last conducted test</p> <p>3.1.15.2 Data review of stored tests</p>
3.1.16	Hardcopy Output	<p>3.1.16.1 Test definition details</p> <p>3.1.16.2 Test Plots</p> <p>3.1.16.3 Post Test messages</p>
3.1.17	Software Licensing	<p>Vendor should clearly spell out the possible options available, like dongle based licensing, computer mach id based licensing, etc.</p> <p>Dongle based license is preferred.</p>

3.2	Random Testing	
3.2.1	Random testing involves excitation of the test specimen with a stationary random signal of a given frequency spectrum and monitoring of the responses at various points.	
3.2.2	Frequency Range	5 Hz to 10KHz.
3.2.3	Number of spectral lines	User selectable from 100 to 3200
3.2.4	Degrees of Freedom of control	10 to 1000
3.2.5	Pretest Levels	User definable from -40 to 0 dB
3.2.6	Startup/Shutdown rate	User definable. Typically between 0 to 24dB/Sec Or Equivalent
3.2.7	Output signal	3.2.7.1 True Gaussian with minimum 3-sigma control 3.2.7.2 Provision for Drive clipping with the following user definable parameter 3.2.7.2.1 Sigma level between 2.5 to 6 OR 3.2.7.1.2 Drive voltage limit : 0.1 V to 10 V
3.2.8	Control Strategy	3.2.8.1 Single Channel 3.2.8.2 Multiple Channel 3.2.8.3 Average 3.2.8.4 Maximum 3.2.8.5 Minimum
3.2.9	Limiting / Abort Setting	3.2.9.1 Automatic limiting of output signal to enable response limitation of specified monitoring Channels. 3.2.9.1 Definition of up to 23 notching / limiting / Abort profiles. 3.2.9.2 Any of the 24 channels, other than control, should be definable as limiting / Abort channel with individual profile.
3.2.10	Control loop Equalization	Equalization within 2 control loops
3.2.11	Control amplitude accuracy	± 1 dB
3.2.12	Averaging type	Linear , exponential
3.2.13	Windowing	Hanning, Keiser Bessel, rectangular, exponential, etc.

3.2.14	Reference spectrum definition	<p>3.2.14.1 Number of Break points or segments > 50</p> <p>3.2.14.1 Definition of any segment by slope or amplitude</p> <p>3.2.14.2 Scaling of the spectrum by defining overall RMS level</p> <p>3.2.14.3 Individual alarm/abort level definition for each segment.</p> <p>3.2.14.4 Importing of reference spectrum from a stored file.</p>
3.2.15	Alarm/Abort	<p>3.2.15.1 User definable number of spectral lines for alarm/abort activation.</p> <p>3.2.15.2 RMS Alarm/Abort definition in terms of dB.</p> <p>3.2.15.3 User definable pretest level, at which alarm/abort definitions are activated.</p>
3.2.16	Display and Analysis features	<p>3.2.16.1 Power Spectral Density function of a given channel.</p> <p>3.2.16.2 Transmissibility - Amplitude & phase transfer function of a channel with respect to another channel.</p> <p>3.2.16.3 Along with the display of the plot of the selected channel, following statistical parameters to be displayed.</p> <p>3.2.16.3.1 Test time.</p> <p>3.2.16.3.2 gRMS,</p> <p>3.2.16.3.3 Maximum and minimum amplitude with frequency.</p>
3.3	Sine Testing	
3.3.1	Test Types	<p>3.3.1.1 Swept Sine Test</p> <p>3.3.1.2 Sine Frequency dwell</p> <p>3.3.1.3 Tracked Resonance dwell – Phase dwelling</p>
3.3.2	Frequency Range	1Hz to 10KHz
3.3.3	Control Strategy	<p>3.3.3.1 Single Channel</p> <p>3.3.3.2 Multiple Channel,</p> <p>3.3.3.3 Average</p> <p>3.3.3.4 Maximum</p> <p>3.3.3.5 Minimum</p>
3.3.4	Sweep definition	<p>In terms of</p> <p>3.3.4.1 Number of sweeps</p> <p>3.3.4.2 Duration</p>

3.3.5	Direction of sweeping	3.3.5.1 Up 3.3.5.2 Down 3.3.5.3 Up Only (in multiple sweeps definition)
3.3.6	Sweep rate	3.3.6.1 Log – 0.1 to 10 Oct/Min 3.3.6.2 Linear – 0.1 to 100 Hz/Min
3.3.7	Drive signal	User definable maximum drive voltage from 0.1V to 10Vpk.
3.3.8	Drive Compression	3.3.8.1 Fixed – Definable between 1 to 300 dB / Sec, OR 3.3.8.2 User definable for different range of frequencies (segment) - between 1% to 100% OR Equivalent
3.3.9	Sweep Accuracy	Better than + 3%
3.3.10	Control amplitude accuracy	+1dB
3.3.11	Frequency Accuracy	3.3.11.1 Equal to or better than +/-0.5 % of test frequency.
3.3.12	Harmonic distortion	3.3.12.1 Better than 60dB at full scale output.
3.3.13	Reference spectrum definition	3.3.13.1 Number of segments > 50 3.3.13.2 Definition of any segment by 3.3.13.3 Acceleration 3.3.13.4 Velocity 3.3.13.5 Displacement 3.3.13.6 Sloped acceleration 3.3.13.7 Individual Alarm & Abort level definition for each segment. 3.3.13.8 Importing of reference spectrum from a stored file.
3.3.14	Startup/Shutdown rate	3.3.14.1 User definable. Typically between 0 to 24dB/Sec OR Equivalent. 3.3.14.2 Level increment greater than 0dB in 0.1dB steps.
3.3.15	Tracking filter	3.3.15.1 Proportional Bandwidth (constant percentage) OR Equivalent. 3.3.15.2 Fixed Bandwidth OR Equivalent.

3.3.16	Notching / Limiting / Abort	<p>3.3.16.1 Automatic notching of output signal to enable response limitation of specified monitoring channels.</p> <p>3.3.16.2 Definition of up to 23 Notching/ Abort profiles.</p> <p>3.3.16.3 Any of the 24 channels, other than control, should be definable as Notching/Limiting/ Abort channel with individual profile.</p>
3.3.17	Display and Analysis features	<p>3.3.17.1 Response function measurement for each channel</p> <p>3.3.17.2 Fundamental (filtered)</p> <p>3.3.17.3 RMS (unfiltered)</p> <p>3.3.17.4 Frequency Response Function (Transmissibility) of each channel w.r.t defined reference channel.</p> <p>3.3.17.5 Fundamental (filtered)</p> <p>3.3.17.6 RMS (unfiltered)</p> <p>3.3.17.7 Phase response, computed with respect to the filtered response, of the channel.</p>
3.3.18	Definitions specific to Dwell, Resonance dwell tests	<p>3.3.18.1 Provision should exist for multiple Dwell frequency definition within a single test</p> <p>3.3.18.2 Dwell duration,</p> <p>3.3.18.3 Dwell range,</p> <p>3.3.18.4 Dwell frequency,</p> <p>3.3.18.5 Dwell phase,</p> <p>3.3.18.6 Dwell level,</p> <p>3.3.18.7 Dwell mode – manual OR automatic.</p>
3.4	Shock Testing	
	The shock testing involves simulating both Classical and SRS, acquiring the transient response and performing the analyses that include SRS (Shock Response Spectrum) analysis and mathematical manipulations that are listed below.	
3.4.1	Classical Shock	
3.4.1.1	Pulse types	<p>3.4.1.1.1 Half Sine</p> <p>3.4.1.1.2 Initial and Terminal Peak Saw tooth</p> <p>3.4.1.1.3 Triangle</p>
3.4.1.2	Pulse duration	0.5 mSec to 2 Sec
3.4.1.3	Pulse Amplitude	1g to 5000g
3.4.1.4	Pre and Post Pulse	Definable in Percentage or Peak g

3.4.1.5	Alarm/Abort	Alarm/Abort tolerances in terms of peak error defined as percentage of maximum amplitude – range 1% to 100%
3.4.1.6	Number of Pulses	1 to 100
3.4.1.7	Duration between Pulses	1Sec to 10 Sec
3.4.1.8	Output polarity	Positive or Negative
3.4.1.9	Output Drive signal	User definable maximum drive voltage from 0.1V to 10Vpk.
3.4.1.10	Equalization of Pulses	3.4.1.10.1 Manual 3.4.1.10.2 Automatic
3.4.1.11	Classical Shock SRS Analysis parameters	3.4.1.11.1 SRS analysis of measurement channels should be possible with classical shock test module with 3.4.1.11.2 User definable 1/nth octave SRS analysis where n ranges from 1 to 24, 3.4.1.11.3 User definable damping ranging from 0.1% to 99%, 3.4.1.11.4 User definable analysis frequency range up to 10KHz. 3.4.1.11.5 SRS Analysis. 3.4.1.11.6 Primary Positive 3.4.1.11.7 Primary Negative 3.4.1.11.8 Primary Maximax, 3.4.1.11.9 Residual and Composite SRS.
3.4.2	SRS Synthesis and analysis	
3.4.2.1	SRS Reference spectrum definition	3.4.2.1.1 Number of Break points or segments should be greater than 50 3.4.2.1.2 Definition of any segment by slope or amplitude 3.4.2.1.3 Individual tolerance band definition for each segment. 3.4.2.1.4 Importing of reference spectrum from a stored file.
3.4.2.2	Synthesis frequency range	25 to 10,000 Hz.
3.4.2.3	Synthesis amplitude range	1 to 10,000 g
3.4.2.4	SRS generation modes	3.4.2.4.1 Wavelet synthesis 3.4.2.4.2 Damped sinusoids synthesis

3.4.2.5	Channels Setup	<p>3.4.2.5.1 In Addition to 3.1.2 above</p> <p>3.4.2.5.2 Provision for selecting sample rate multiplier or sampling frequency</p> <p>3.4.2.5.3 Time duration of the record,</p> <p>3.4.2.5.4 Type of triggering.</p>
3.4.2.6	Alarm/Abort	3.4.2.6.1 Alarm/Abort tolerances in terms of peak error defined as percentage of maximum amplitude – range 1% to 100%
3.4.2.7	Drive signal	3.4.2.7.1 User definable maximum drive voltage from 0.1V to 10Vpk.
3.4.2.8	SRS analysis of Time domain Analysis of Time Domain Signal	<p>The following parameters should be user selectable for the purpose of Acquisition and Analysis</p> <p>3.4.2.8.1 User definable analysis frequency range up to 10KHz.</p> <p>3.4.2.8.2 User definable 1/nth octave SRS analysis where ‘n’ ranges from 1 to 24,</p> <p>3.4.2.8.3 User definable damping ranging from 0.1% to 99%,</p> <p>3.4.2.8.4 SRS /all and Composite SRS.</p>
4	PC Projection	<p>4.1 The system should be able to interface to the projector system projecting the master screen with master/slave monitors enabled for viewing.</p> <p>4.2 The vendor should clearly bring out any issues in interfacing the control system the projector.</p> <p>4.3 Quote should be given separately if any additional system are required for connecting the projector</p>

III. TECHNICAL SPECIFICATIONS

Vibration Data Acquisition System

1.0 Vibration Data Acquisition System

1.1 Introduction

1.1.1 The Vibration Data Acquisition System will be used for acquiring and performing analysis of vibration data obtained during Vibration Testing of satellite propulsion subsystems.

1.1.2 The system is required to support a minimum of 48 channels of voltage and acceleration with provision for further expansion. Both software and hardware are required to be highly modular in structure to render the operation and maintenance easier. The modularity is required for easy scalability of the system for future requirements.

1.2 Digital Data Acquisition system should be any one of the following make and model which were qualified by LPSC(B) / URSC

1.2.1 Scadas from M/s Siemens PLM (or)

1.2.2 Vib-runner from M/s M+P (or)

1.2.3 Abacus Signal Star-Vector from M/s Data Physics

2.0 Hardware

2.1 Instrumentation Front End

<i>Sl. No.</i>	<i>Features</i>	<i>Range/value</i>
2.1.1	Number of Input Channels	Minimum of 48 channels with provision for future expansion up to 96 channels
2.1.2	Input/output connectivity to instrumentation front end	2.1.2.1 BNC Connector. 2.1.2.2 If BNC connectors are provided on a breakout box, these breakout boxes should be mounted on a 19" rack panel for ensuring rigid support.
2.1.3	Interface to Computer	High speed connectivity such as Ethernet or Firewire between the instrumentation front end and the computer. The connectivity should support the high data rate emanating from 100KHz sampling rate, 24 bit ADC and 48 channels (resulting in transfer rate of 19.2 MB/Sec or better)
2.1.4	Calibration	2.1.4.1 It should be possible to carry out ON-SITE Instrumentation front-end calibration without the need of support/intervention from the vendor. 2.1.4.2 Any H/W & S/W accessories for the same shall be provided along with the system. 2.1.4.3 Offset removal and gain linearity adjustment for all the input/output channels should be provided. 2.1.4.4 In case if any channel fails in calibration, the calibration process should continue skipping that particular channel. It should be possible to isolate/disable the failed channel in further calibration steps.

2.2 Computer

<i>Sl. No.</i>	<i>Features</i>	<i>Range/value</i>
	Vendor has to ensure that the computer platform chosen is sufficient to meet overall functional requirement of control system	
2.2.1	Operating System	Microsoft Windows-10 Professional 64-bit or better or Linux with support.
2.2.2	Platform	2.2.2.1 Intel i7-4790 3.6 GHz (8 cores) Processor or Better 2.2.2.2 Suitable high speed system bus or better. 2.2.2.3 Intel/OEM Chipset on OEM motherboard compatible with quoted processor.
2.2.3	RAM	2.2.3.1 Minimum 32 GB DDR4 RAM or better. 2.2.3.2 System shall support memory extension up to 64 GB. 2.2.3.3 Minimum Two DIMM slots shall be free after configuring all the required memory modules. Specify total and occupied DIMM slots. 2.2.3.4 Vendor shall configure memory DIMM as per the best practices specified by processor OEM for the best and balanced performance.
2.2.4	Hard disk	2.2.4.1 1 set (2 numbers) of 2TB (min.) or better HDD with RAID 1 (disk mirroring) feature for OS & application software. 2.2.4.2 1 set (2 numbers) of 2TB (min.) or better HDD with RAID 1 (disk mirroring) feature for data storage. 2.2.4.3 The hard disk shall be with SATA interface; e-SATA/NL-SAS interfaces are preferred. 2.2.4.4 The hard disk shall be divided into two logical drives one for OS/application software and another for data. 2.2.4.5 Monitors shall be of Non-Touch type.
2.2.5	Monitor	2.2.5.1 One 28" full HD LED monitor with 1920 x 1080 resolution or better 2.2.5.2 One 24" full HD LED monitor with 1920 x 1080 resolution or better 2.2.5.3 These monitors shall be connected in Dual Mode configuration
2.2.6	DVD-R/W Drive	16X or better DVD Super Multi double-layer drive with DVD and CD read-write capability.

<i>Sl. No.</i>	<i>Features</i>	<i>Range/value</i>
2.2.7	I/O ports	<p>2.2.7.1 USB ports – minimum 6 nos., out of which minimum 2 should be USB 3.0 or better.</p> <p>2.2.7.2 Display Port – Two Nos. Apart from connecting the computer to display monitors, provision should be provided to simultaneously connect the computer to standard Projectors available in the market</p>
2.2.8	Pointing Device	USB Optical Scroll mouse.
2.2.9	Keyboard	Full sized keyboard with integral numeric keypad.
2.2.10	Networking	<p>2.2.10.1 Minimum 1Gbps Ethernet port. LAN speed should be sufficiently large enough to support the high data rate described in 2.1.14.</p> <p>2.2.10.2 One Additional 1Gbps Ethernet port to connect computer to LPSC(B) network.</p> <p>2.2.10.3 One 8/12 port 1Gbps unmanaged network switch should be mounted in the rack provided with the quoted system.</p> <p>2.2.10.4 The network port shall be RJ45connector</p>
2.2.11	Additional Display Port	2.2.11.1 One number, Apart from connecting the computer to display monitors, shall have provision to simultaneously connect the computer to standard high resolution external LED display or external projector.
2.2.12	Graphics	<p>2.2.12.1 Integrated dual graphics supporting FHD resolution. Video interface: Display Port, HDMI</p> <p>2.2.12.2 Graphics card shall support simultaneously three displays in the following configuration</p> <p>2.2.12.2.1 Two monitors in Dual Mode configuration.</p> <p>2.2.12.2.2 One for external projector or high resolution external LED display with HDMI interfaces to display the content of one of the dual monitors.</p>
2.2.13	Licensing and recovery of OS	The OS to be supplied i.e. Windows should be licensed with license key. OS Recovery and Driver DVD to be supplied.
2.2.14	Removable Hard disk	2.2.14.1 2 nos. of 2TB removable HDD with USB interface for data portability.

<i>Sl. No.</i>	<i>Features</i>	<i>Range/value</i>
2.2.15	Printer and scanner	<p>2.2.15.1 1 No. of Color Laser jet Printer with scan function, built-in USB & network port, with automatic duplex (double side) printing capability, Paper size: A4, printing speed of minimum of 30 PPM and resolution of minimum of 600 dpi.</p> <p>2.2.15.2 The printers shall be of latest model, supplied with Indian warranty and shall be locally serviceable.</p>

3.0 Software

3.1 Basic System Software Features

<i>Sl. No.</i>	Features
3.1.1	The software should cater for acquisition, throughput recording, analysis and report generation of vibration data for satellite propulsion subsystem. Software license provided for all modules should be on perpetual basis.
3.1.2	Software should support on-line acquisition and throughput of time domain data of all the channels with the maximum sampling rate during all modes of test data acquisition using built-in throughput disk.
3.1.3	Software should support simultaneous on-line acquisition, analysis, display and storage of both time and frequency domain data during sine, random and shock tests. It should also support post processing of raw time domain data both in frequency domain and in time domain.
3.1.4	The software should be able to display entire time domain data of selected Channels in a single plot during post processing.
3.1.5	Provision should exist for selecting the channels randomly for acquisition.
3.1.6	Following pre-acquisition parameters should be user selectable in spreadsheet style setup in all the software packages. <ul style="list-style-type: none"> 3.1.6.1 Setting-up of measurement channels before the start of acquisition process. 3.1.6.2 Manual Input of calibration factor, channel sensitivity. 3.1.6.3 Provision should exist for tagging each of the channels with user defined channel names and accelerometer directions such as +x, -x, +y, -y, +z, -z. 3.1.6.4 Amplitude conversion factor to convert incoming signal voltage to Engineering Unit.
3.1.7	Following features should be available with respect to pre-acquisition setup. <ul style="list-style-type: none"> 3.1.7.1 Storing of channel configuration data in file for future recall. 3.1.7.2 Printing of channel parameters. 3.1.7.3 Storing of the setup parameters along with the data after acquisition. 3.1.7.4 Importing of setup parameters from MS Excel file / ASCII file.

<i>Sl. No.</i>	Features
3.1.8	Method of Data Capture (Trigger) <ul style="list-style-type: none"> 3.1.8.1 Through manual command using keyboard/mouse. 3.1.8.2 Transient triggering by waiting for a transient (impulse) to occur before acquiring the data. 3.1.8.3 Positive, Negative and Bi-polar trigger signal.
3.1.9	Time duration of acquisition for throughput at maximum sampling rate on all channels – Minimum of 600 seconds.
3.1.10	Provision should exist for time domain data display of all channels for the purpose of verification prior to acquisition
3.1.11	Following display features should be provided in all the software packages.
3.1.12	Data of a single channel should be displayable with option for peak picking.
3.1.13	Provision for data display in a single window for comparison either with over-plotting, or with tiled display of <ul style="list-style-type: none"> 3.1.13.1 Multiple channels of single test (i.e. within the same set of data) 3.1.13.2 Multiple channels data from multiple tests 3.1.13.3 Data of multiple channels of single and multiple tests should be displayable in multiple windows.
3.1.14	Waterfall display of the selected channel.
3.1.15	Zooming of a selected band in the graph should be possible.
3.1.16	Data tracking cursor for identifying graph values should be provided. It should be possible to mark multiple peaks using single cursor.
3.1.17	Automatic peak picking in the selected range of frequency and amplitude. Provision for manual peak picking to add additional peaks along with automatically picked peaks.
3.1.18	Manual & Automatic setting of the range for X and Y-axes.
3.1.19	Option to set Linear/logarithmic scale for X and Y-axes.
3.1.20	Option to enable/disable grid lines.
3.1.21	Hard copy printing option for all the above display plots. Software should be able to support the general LaserJet printers and in particular the Color LaserJet printer supplied along with the system.
3.1.22	Batch printing of selected channels with automatic peak picking in selected range of frequency and amplitude
3.1.23	<ul style="list-style-type: none"> 3.1.23.1 Facility should be present to save the display plots in PDF format as well as Microsoft word or equivalent format for report generation purpose. 3.1.23.2 It should be possible to export all plots of a test at once to MS word or equivalent with optional peak picking for each of the plots.

<i>Sl. No.</i>	Features
3.1.24	Option to list identified points on the graph along with the graph should be available. This feature should be supported in hard copy generation also.
3.1.25	The software should support export of time data in binary and processed data files in ASCII and binary formats of the following format definitions 3.1.25.1 Universal File Format – data set 58/58B and other data sets. 3.1.25.2 Spread sheet format (Microsoft Excel or equivalent). 3.1.25.3 ASCII format. 3.1.25.4 MATLAB Binary and MATLAB ASCII. Importing of time and processed data in Universal File Format – data set 58/58B should be possible.
3.1.26	Provision for initial diagnostics of the instrumentation front end in case of any hardware problems.
3.1.27	Provision for on-site Instrumentation Front-end Calibration should be provided with Calibration Software and associated accessories for field calibration as per specification 2.16.
3.1.28	Provision to view the time and processed data in any other computer connected to LAN of LPSC-Bengaluru

3.2 Random Data Analysis

<i>Sl. No.</i>	Features
3.2.1	The Software module should support data acquisition, analysis and storage of the responses monitored at various locations on the test specimen during random vibration test.
3.2.2	Real time FFT operation to be performed and displayed to obtain frequency domain transformation of the time domain signal.
3.2.3	Following pre-acquisition parameters should be user selectable. These are in addition to the parameters described above in section 4.1 (Basic System Software Features).
3.2.4	Frequency Range selectable from 0 – 10Hz to 0 – 40KHz in discrete steps.
3.2.5	Sampling rate selectable from 25 to 100KHz in discrete steps.
3.2.6	Number of spectral lines – 200 to 16384.
3.2.7	Number of averages – 1 to 1000.
3.2.8	Type of Averaging. 3.2.8.1 Linear 3.2.8.2 Peak Hold 3.2.8.3 Exponential averaging 3.2.8.4 No Averaging
3.2.9	FFT overlap definable in percentage from 0% to 90%
3.2.10	Windowing function

<i>Sl. No.</i>	Features
	3.2.10.1 Hanning 3.2.10.2 Keiser Bessel 3.2.10.3 Rectangular 3.2.10.4 Exponential
3.2.11	Off-line analysis of the stored time domain data should be possible. In off-line analysis, it should be possible to perform analysis with frequency range that is lower than the one defined during acquisition.
3.2.12	The following analysis features should be possible in both on-line and offline. <ul style="list-style-type: none"> 3.2.12.1 Power Spectral Density function of a given channel 3.2.12.2 Cross spectral density function between any two channels 3.2.12.3 Auto Correlation of a given channel and cross correlation between any two channels 3.2.12.4 Coherence function (defining the linear dependency between two signals over a given frequency range) between any two channels 3.2.12.5 Computation of RMS values for selected band of frequency 3.2.12.6 Octave analysis with option to select order of analysis from 1/1 Octave to 1/24 octaves or better. 3.2.12.7 Phase spectrum between any two channels 3.2.12.8 Real and imaginary plot (with respect to frequency) of a spectral density function for any channel 3.2.12.9 Transmissibility (FRF) – amplitude and phase transfer function of a channel with respect to another channel 3.2.12.10 Along with the display of the plot of the selected channel, statistical parameters such as rms, maximum and minimum amplitude with frequency, etc., should be displayed The following analysis features should be supported in off-line analysis mode. <ul style="list-style-type: none"> 3.2.12.11 Integration 3.2.12.12 Differentiation of a given channel
3.2.13	Printing options must be provided as described above in section 3.1.21 (Basic System Software Features).

3.3 Sine Data Acquisition and Analysis

<i>Sl. No.</i>	Features
3.3.1	The system should support swept sine data analysis. The Software module should support data acquisition and analysis of the responses monitored at various locations on the test specimen during swept sine test. Simultaneous on-line acquisition, recording and analysis (as per section 4.3.2 below) of the time-domain data in real time should be possible. (OPTIONAL)

<i>Sl. No.</i>	Features
3.3.2	The acquisition process should adopt frequency estimation technique where, instantaneous frequency information is obtained by counting the number of zero crossings in a frequency reference signal and computing the frequency value or equivalent. Amplitude of all the data channels should be obtained by estimating the instantaneous amplitude value of the corresponding channels.
3.3.3	Both filtered response (the response at the fundamental excitation frequency only, with the contributions of other frequencies removed) and overall or unfiltered response (response over the entire selected frequency range) should be computed and stored separately along with the phase information. It is preferred to have simultaneous computation of both filtered and unfiltered responses.
3.3.4	The phase response of a given channel should be computed with respect to the filtered response of the channel.
3.3.5	The bandwidth selected for computation of the filtered response (amplitude) can be either, <ul style="list-style-type: none"> 3.3.5.1 Proportional Bandwidth 3.3.5.2 Fixed Bandwidth.
3.3.6	Provision should exist to concatenate minimum of THREE runs of a single swept sine test for the purpose of display and plotting of both filtered and unfiltered data in a single plot
3.3.7	Off-line analysis of the stored time domain data should be possible. In off-line analysis, it should be possible to perform analysis with frequency range that is lower than the one defined during acquisition by applying user definable low pass filter.
3.3.8	Following pre-acquisition parameters should be user selectable. These are in addition to the parameters described above in section 3.1 (Basic System Software Features).
3.3.9	Frequency Range from 5Hz to 20KHz with corresponding sampling rate from 12.5Hz to 100KHz
3.3.10	Direction of sweeping. <ul style="list-style-type: none"> 3.3.10.1 Up – where the test starts from the given low frequency limit to the set maximum frequency. 3.3.10.2 Down – where the test starts from the given maximum frequency limit to the set minimum frequency. 3.3.10.3 Free run – where the test can sweep in either direction.

<i>Sl. No.</i>	Features
3.3.11	<p>Display and analysis features include:</p> <ul style="list-style-type: none"> • Response spectrum – Amplitude of the response channel versus frequency with filtered response (the response at the fundamental excitation frequency only, with the contributions of other frequencies removed) and overall response (Broadband RMS) options. • Frequency Response Function (FRF – Transmissibility) – both with overall and filtered response options. Option to display the phase with FRF should exist.
3.3.12	Printing options must be provided as described above in section 3.1.21 (Basic System Software Features).

3.4 Transient Data Acquisition and Analysis

<i>Sl. No.</i>	Features
3.4.1	The system should support acquisition and processing of transient data as well as to process the data stored in disc, both in time and frequency domains.
3.4.2	<p>Following pre-acquisition parameters should be user selectable apart from those described above in section 4.1 (Basic System Software Features).</p> <p>3.4.2.1 Sampling rate up to the maximum limit of 100 KHz.</p> <p>3.4.2.2 Time duration of Acquisition</p>
3.4.3	<p>It should be possible to carry out the following operations on the time domain signal before computing SRS.</p> <p>3.1.1.1 Filtering of the signal with low pass / band pass filters with user defined cut-off frequencies.</p> <p>3.1.1.2 DC offset removal (wavelet based DC Offset removal technique may also be provided as an option)</p> <p>3.1.1.3 Trend removal.</p>
3.4.4	<p>Shock</p> <p>Response Spectrum (SRS) Analysis with following parameters user selectable.</p> <p>3.4.4.1 Damping – 1 to 99%.</p> <p>3.4.4.2 Frequency Range – up to 20 KHz.</p> <p>3.4.4.3 Octave analysis Definition</p> <p>3.4.4.3.1 1/1 Octave</p> <p>3.4.4.3.2 1/3rd Octave</p> <p>3.4.4.3.3 1/6th Octave</p> <p>3.4.4.3.4 1/12th Octave</p> <p>3.4.4.3.5 1/24th Octave</p>

3.4.5	Display of following SRS plots with option of displaying them in a single window (either overlapping of the SRS plots or displaying one next to another) along with time domain signal. Primary, Residual, Positive, Negative and Maximax SRS.
3.4.6	Overlap user defined reference and tolerance bands along with SRS plot of acquired shock data
3.4.7	Off-line analysis of the stored time domain data should be possible.
3.4.8	Printing options must be provided as described above in section 4.1 (Basic System Software Features).

3.5 Mathematical Processing

<i>Sl. No.</i>	Features
3.5.1	Following operations should be possible on acquired raw time domain data and processed data.
3.5.2	Data-Data arithmetic (+, -, * and /) between any two selected channels.
3.5.3	Data-Constant arithmetic (+,-,* and /) for a selected channel with data in real/complex/magnitude-phase format.
3.5.4	Integration and differentiation of a given channel data.
3.5.5	Signal manipulation such as Append signal to Dataset, Copy whole signal, Extract named elements, Repair signal, Replace signal, Include signals to dataset, Copy section of signal, etc.
3.5.6	Filtering operations – low pass, high pass, band pass and band stop – with Bessel and Butterworth filter characteristics.
3.5.7	Ability to add user defined routines using built-in programming environment or routines developed using MATLAB/C/C++/Java programming environments. It should be possible to invoke these user defined routines within the acquisition and analysis packages defined above.
3.5.8	It should be possible to re-process time domain data that is modified using the above mathematical tools in random/sine/transient analysis modules.

<i>Sl. No.</i>	<i>Features</i>	<i>Range/value</i>
3.6	Electrical Power Supply & Operating Environment The supplied hardware should be able to run with the following electrical supply and environmental conditions. The vendor should supply the system with India compatible power-cords.	
3.6.1	Electrical Supply	
3.6.1.1	Voltage	220 Volts AC +5% and -10%
3.6.1.2	Frequency	50 Hz \pm 1.5%
3.6.2	Operating Environment	
3.6.2.1	Operating and storage temperature	15°C to 35°C
3.6.2.2	Relative Humidity	20% to 80%

IV. TECHNICAL SPECIFICATIONS

Vibration Signal Conditioner

1.0 Signal Conditioner Unit

Sl. No	Parameters	Specifications
1.1	Make and Model	Oasis from M/s MEGGIT, USA (or) 2964 A from M/s Bruel & Kjeear, Denmark
	1.1.1 Inputs	IEPE / Voltage Input
	1.1.2 No of channels	48
1.2	Connectors and interfaces	
	1.2.1 Input connectors	BNC
	1.2.2 Output connectors	BNC (For connectors other than BNC, suitable cable of 15 m length with BNC terminations to be supplied or 19" rack mountable breakout box with BNC connectors for each channel output to be supplied.)
	1.2.3 Digital control interface	1.2.3.1 Front panel settable / Settings from PC through RS-232/USB/LAN. 1.2.3.2 Multiple units may be settable through master slave configuration. In such case the cable length should be around 15 m from PC to Master unit (in case of RS232/LAN) and the cable length should be around 1m between master unit to slave unit.
1.3	PC and Application software:	
	1.3.1 PC and operating system	1.3.1.1 One computer to control all signal conditioning units. 1.3.1.2 The Computer should have a reliable Operating system supporting the interface software for the signal conditioner unit.
	1.3.2 Processor	Intel Core I7 or better
	1.3.3 RAM	32 GB, DDR3 or more

Sl. No	Parameters	Specifications
	1.3.4 Hard disk	1.3.4.1 2 TB or better 1.3.4.2 The hard disk should be divided into two logical drives one for OS/application software and another for data.
	1.3.5 Monitor	One 32" full HD TFT LED monitor.
	1.3.6 DVD-R/W Drive	24X or better DVD Super Multi double-layer drive with DVD and CD read-write capability.
	1.3.7 I/O ports	1.3.7.1 USB ports ver. 3.0 minimum of 6no. 1.3.7.2 RS232 interface ports – minimum of 2nos.
	1.3.8 Pointing Device	USB Optical Scroll mouse.
	1.3.9 Keyboard	Space saver ergonomic keyboard with 104 keys or better.
	1.3.10 Networking	1 Gbps Ethernet port. (In case, the signal conditioner system uses Ethernet port to communicate to PC for parameter settings, additional 1Gbps Ethernet port to be provided for connecting to the local intranet.)
	1.3.11 Application software	The application software should interface the signal conditioner unit to the PC for setting various parameters. The software CD/DVD should be provided for each unit.
1.4	Others	
	1.4.1 Operating Temperature	15°C to 35°C
	1.4.2 Voltage	90- 230 V AC or suitable power adaptor.
	1.4.3 Frequency	50 Hz \pm 1.5 %

V. TECHNICAL SPECIFICATIONS

Accelerometers and Cables

1.0 Accelerometer Specification

Sl. No	Description	Type – 1	Type – 2	Type – 3	Type-4
1	Sensitivity	100 mv/g	50 mv/g	10 mv/g	10 mv/g
2	Make and Model No.	1. ENDEVCO Model No. 41A16-1032 (or) 2. DYTRAN Model No. 3056D2 (or) 3. B&K Model No. 4533-B-001 (or) 4. KISTLER Model No. 8704B50M1	1. DYTRAN Model No. 3056D5 (or) 2. B&K Model No. 4534-B-004	ADHESIVE BONDING TYPE: 1. ENDEVCO Model No. 41A13-1032 or 2. PCB: 352c43 3. Dytran: 3225F2 4. PCB: 355B02 5. B&K: 4517C002 STUD TYPE: 1. KEISTLER: 8704B500	1. DYTRAN Model: 3023A 2. KISTLER Model: 873B500BB 3. B&K Model: 4520 4. PCB Model: 356B21 5. ENDEVCO Model:65-10-R (Cable of 10 m length terminated to 10-32 UNF male to be supplied)
3	Qty	10	15	20	20

2.0 Cables for Accelerometers

Sl. No	Description	Type – 1	Type – 2
1	Make and Model No	M098EB060PW from PCB, USA/ or C-001-AA-002-2400 from Meggitt- Endevco, USA	M098EB010EB from PCB, USA/ or C-001-AA-001-0394 from Meggitt- Endevco, USA
3	Cable Length	60meters	10meters
4	End Connection	10-32UNF male at one end and BNC male connector at the other end with strain relief on both ends.	10-32UNF male with strain relief on both ends.
4	Qty	100	100

3.0 Isolation Studs

Sl. No.	Description	
1	Make	MEGGITT
3	Model No	2986B
4	Thread Size, Accelerometer side	10-32 UNF male
5	Thread Size, mounting side	10-32 UNF male
4	Qty	50

VI. WARRANTY AND SUPPORT

Note: The Vendor should provide 3% PBG (performance Bank Guarantee) for entire warranty period.

1	Shaker System
	<p>1.1 One-year comprehensive On-site Warranty from the date of Acceptance of the system.</p> <p>1.2 Extended warranty for 3 years after completion of standard 1-year warranty with break up for 1st year, 2nd year and 3rd year should be quoted separately.</p> <p>1.3 The technical response to problem solving through phone/mail should be provided within 24 hrs of fault reporting.</p> <p>1.4 Fault should be resolved on site within 7 working days of fault reporting.</p>
2	Digital Control and Data Acquisition System
	<p>2.1. One-year comprehensive On-site Warranty for the Hardware and Software from the date of Acceptance of the system.</p> <p>2.2. Extended warranty AMC for 3 years after completion of standard 1-year warranty with break up for 1st year, 2nd year and 3rd year should be quoted separately.</p> <p>2.3. Software support with bug-fixing versions shall be maintained for a minimum period of SEVEN Years.</p> <p>2.4. Post-sales support (operation support and maintenance) available locally should be spelt out clearly. Availability of the local support will form the basis for technical qualification of the system.</p> <p>2.5. The vendor should support spares for seven years from the date of installation.</p> <p>2.6. Software for installation shall be provided in a CD-ROM/DVD-ROM. In case of a failure of the host-work-station, the software shall be capable of being installed on a stand-by host-work-station to ensure 100% uptime.</p>
3	Signal Conditioners
	<p>1.1 One-year comprehensive On-site Warranty from the date of Acceptance of the system.</p> <p>1.2 Extended warranty AMC for 3 years after completion of standard 1-year warranty with break up for 1st year, 2nd year and 3rd year should be quoted separately.</p>

VII. INSTALLATION AND TRAINING

<p>1.0 Shipping and Installation</p>	<p>1.1 All the systems shall be installed at ITPF Campus, LPSC B)/ ISRO, Tumkur, INDIA.</p> <p>1.2 The Vendor shall install the Shaker system, Vibration Control System, Data Acquisition System Signal Conditioner and all auxiliary units in the areas already identified in the building.</p> <p>1.3 The shaker system will be installed 1m below the floor level. The design of the oil, cooling water and pneumatic circuit should be taken care accordingly.</p> <p>1.4 The supplier or their representative should take full responsibility for unloading, unpacking, installation, commissioning, carrying out acceptance tests and handing over the system at ITPF.</p> <p>1.5 Electrical wiring from the Power distribution panel to the Power Amplifier, cooling unit, hydraulic units, other auxiliary systems and hydraulic connections shall be the responsibility of the vendor.</p> <p>1.6 The vendor shall have responsibility of providing required connecting cables, hoses and pneumatic lines routed through a Junction Box using Quick Connect Connectors. Utility outlets for power and air will be provided by LPSC, Bengaluru, at locations identified by vendor.</p>
<p>2.0 Factory Acceptance Testing (FAT) and Inspection(As per annexure-2)</p>	<p>2.1 Shaker system along with the Control System, Data Acquisition System and associated instrumentation elements covered in this tender should be should be fully integrated and tested prior to dispatch and these test results shall be made available to LPSC for perusal.</p> <p>2.2 LPSC(B)at its own discretion may inspect and witness the pre-shipment factory tests. Minimum one month advance intimation shall be given for the FAT tests.</p>
<p>3.0 Site Acceptance tests (SAT) (As per annexure-3) to be carried out at ITPF will be the basis for acceptance of the system.</p>	<p>3.1 Shaker system along with the Control System, Data Acquisition System and associated instrumentation elements covered in this tender should be should be fully integrated, commissioned and tested as per the Site Acceptance test procedure at ITPF. Satisfactory completion of the SAT will form the basis for acceptance the system.</p>
<p>4.0 Training at LPSC(B)</p>	<p>4.1 Supplier should provide mandatory training on operation and routine maintenance of the system to LPSC(B) personnel at ITPF as part of installation and commissioning.</p> <p>4.2 The supplier shall provide training to LPSC personnel for safe operation and maintenance of the shaker system</p>

VIII. TERMS & CONDITIONS

1.0 Offer should be submitted in two parts. **Part-I is the “Techno commercial part”** and **Part-II is the “Price part”**. Both parts to be submitted separately.

2.0 PART-I (Techno Commercial part)

Techno commercial part should consist of following two sections:

2.1. Technical

- 2.1.1 Detailed technical specifications of the items.
- 2.1.2 Standard options for quoted systems.
- 2.1.3 Standard accessories etc.
- 2.1.4 Specified options
- 2.1.5 Catalogues, technical manuals, and related literature
- 2.1.6 Technical compliance statement as per **annexure 4**.
- 2.1.7 List of deliverables.
- 2.1.8 Vendor must provide the details of international quality standards which are followed at manufacturing works.
- 2.1.9 Supply heritage: List of installations with contact details.

2.2. Commercial

Note: Part 1 should not contain any price details.

All the following commercial terms (other than price) should be specified in this section in the following format.

Sl. No.	Description	Confirm /Specify
1.	Electrodynamic shaker system	
	Individual break up costs viz. Shaker, Slip table, Amplifier and Load bearing Platform etc.	Yes/No
2.	Control System	Yes/No
3.	Data Acquisition System	Yes/No
4.	Accelerometers	Yes/No
5.	Accelerometer Cables	Yes/No
6.	Optional Accessories if any (give description)	Yes/No
7.	Recommended special purpose tools and tool kit for operation & maintenance. (quantity of each tool required to be mentioned)	Yes/No
8.	Installation charges	Yes/No
9.	Comprehensive AMC for 3 years after completion of standard 1-year warranty with break up for 1st year, 2nd year and 3rd year should be quoted separately.	Yes/No
10.	Delivery period	12 months
11.	Validity period: Both the technical and commercial offers of the vendor should be valid for a minimum period of 120 days from the due date of opening of the tender.	
12.	Approximate system weight	To be specified

- 3.0 Table of compliance statement (as per the format given in annexure 4) giving exact numerical values with tolerances or range of values should be supplied along with the quote without which the quote will not be considered. Merely stating, “comply” does not constitute sufficient technical data. **In case of insufficient technical data, the quote will be summarily rejected without seeking any clarifications.**
- 4.0 The quoted system should have proven heritage without which the offer will not be considered
- 5.0 Specified technical data should be supported by product catalogs, manuals, test procedures, and test plots etc.
- 6.0 Vendor shall be ready to give a techno-commercial presentation at LPSC if required.
- 7.0 **Specified options** will be exercised at the time of order and hence should be quoted separately. The vendor may quote separately for any other options necessary to meet the performance specifications.
- 8.0 Minor modifications that are necessary to meet LPSC(B) interface requirements should be accommodated while executing the order.
- 9.0 Vendor shall provide basic training related to operation & maintenance and troubleshooting of shakers for LPSC(B) Engineers on site after installation.
- 10.0 **Utilities:** the vendor to specify the various requirements of operation & installation of the shaker system
 - 10.1 Electrical Power requirements.
 - 10.2 Civil requirements like footprint of various systems, minimum area required for entire system like field power supply etc.
 - 10.3 Cooling system requirements like temperature, flow rate, termination details etc
 - 10.4 AC requirements like heat dissipation factor for each subsystem
 - 10.5 Foundation requirement for installation, trench requirement etc
 - 10.6 Additional features if any may be indicated separately and quoted as optional.

IX. SCOPE OF WORK AND SUPPLY

SCOPE OF WORK

The scope of work and responsibility of supplier include Design, Manufacture, handling at site, integration and demonstration of total integrated system performance as per specifications.

Scope of supply	
1.1.	Supply of complete Shaker system as per specifications
1.1.1.	Shaker
1.1.2.	Slip Table
1.1.3.	Amplifier
1.1.4.	Field Power Supply
1.1.5.	Cooling Unit
1.1.6.	Head Expander
1.1.7.	Adaptors Plates
1.2.	Supply of Digital Control System as per specifications
1.2.1.	24 channel Hardware
1.2.2.	Computer
1.2.3.	Printer and scanner
1.2.4.	Sine data acquisition and analysis software
1.2.5.	Random data acquisition and analysis software
1.2.6.	Transient data acquisition and analysis software
1.2.7.	MIMO software
1.2.8.	Calibration software
1.2.9.	Media of Installation software Software for installation shall be provided in a CD-ROM/DVD-ROM. In case of a failure of the host-work-station, the software shall be capable of being installed on a stand-by host-work-station to ensure 100% uptime.
1.2.10	RACK for mounting Standard portable rack for housing Instrumentation Front-end should be supplied, providing Minimum 1U gap between modules for Thermal Dissipation

1.3.	Supply of Digital Data Acquisition System as per specifications
1.3.1.	48 channel Hardware
1.3.2.	Computer
1.3.3.	Printer and scanner
1.3.4.	Sine testing software
1.3.5.	Random testing software
1.3.6.	Shock testing software
1.3.7.	Calibration software
1.3.8.	Media of Installation software The vendor should supply the Application Software and Operating system software in CD-ROM/DVD-ROM. In case of a failure of the host-work-station, the software shall be capable of being installed on a stand-by host-work-station to ensure 100% uptime.
1.3.9.	RACK for mounting Portable rack on wheels for housing Instrumentation Front-end should be supplied.
1.4.	Supply of Signal Conditioners as per the specification
1.4.1.	48 channel Hardware
1.4.2.	Computer
1.4.3.	RACK for mounting Portable rack on wheels for housing Instrumentation Front-end should be supplied.
1.5.	Supply of Accelerometers and Cables
1.6.	Carrying out acceptance tests at factory as per annexure-2
1.7.	Carrying out acceptance test at ITPF, Tumkur as per annexure-3
1.8.	Training at ITPF
1.9.	Two sets of Documentation in English Shaker system 1.9.1. Operation manual 1.9.2. Service manual 1.9.3. Electrical wiring and mechanical schematics, dimensioned drawings. 1.9.4. Parts list.

	<p>1.9.5. System specifications including subsystems, subsystem data sheets, interface requirements, calibration requirements and procedures</p> <p>1.9.6. AutoCAD assembly drawings of shaker slip table and head Expander</p> <p>1.9.7. Factory test results.</p> <p>Digital Control system</p> <p>Hard copy User Manual and Service documentation should be provided for</p> <p>1.9.8. Instrumentation front end</p> <p>1.9.9. Application Software</p> <p>1.9.10. Computer hardware</p> <p>1.9.11. Service Manual</p> <p>Data Acquisition system</p> <p>Hard copy User Manual and Service documentation should be provided for</p> <p>1.9.12. Instrumentation front end</p> <p>1.9.13. Application Software</p> <p>1.9.14. Computer hardware</p> <p>1.9.15. Service Manual</p> <p>Signal Conditioner</p> <p>1.9.16. Operation and service manual with circuit schematic should be provided.</p>
<p>1.10.</p>	<p>Warranty certificate</p>
<p>1.11.</p>	<p>Certificate of origin. Details should be provided along with the offer.</p>

Annexure-2

Factory Acceptance Test (FAT) Plan at factory prior to dispatch

Shaker system along with the quoted Control System, should be tested as per the following test requirements. All accelerations channels should be connected both to control system and data acquisition system.

Shaker and amplifier should be tested individually (as single shaker system configuration) as well as in dual mode configuration along with dual head expander and 2.5 m slip table. **Push-push shall be demonstrated with fully integrated control system, data acquisition system and associated instruments as quoted in the tender offer.**

Typical Control System Settings

Sine:

- Frequency range: As per the test plan
- Test Level: As per the test plan
- Control strategy: Maximal control in case of multi point control
- Compression factor: Typical 100 % / 4 [m/s Spectral Dynamics / M/s Siemens (LMS)]
- Alarm & Abort: +/- 3 & +/- 6
- Sweep rate: As per the test plan
- Control estimator: BBRMS / RMS
- Start rate or start up time: 10 dB / sec or 2 sec
- COLA: to be available for data acquisition system

Random:

- Frequency range: As per the test plan
- Test Level: As per the test plan
- Control strategy: Maximal control in case of multi point control
- DOF: 120
- Alarm & Abort: +/- 3 & +/- 6
- Test duration: As per the test plan
- Resolution: 5 Hz
- Processing Window: Hanning

- Averages: 16

DAS Settings for Acquisition:

- Sampling rate: for sine 12.8 KHz, 6400 Hz for random
- Processing Window: Hanning
- Averages: 16
- COLA: to be recorded

**Individual Shaker System Configuration with quoted Control system
(All the Test to be carried on the both the shaker system independently)**

BARETABLE

1. Resonance test (Pre-signature)

1g Constant control.

Frequency: 5 Hz to 2000 Hz at 2 Oct/min. Control at centre of armature.

- 1.1. Plot response accelerations for all three axes at locations shown in Figure-1. (DAS)
- 1.2. Plot Control, Drive, Armature current, and Armature voltage (CS).

2. Max displacement, Max Velocity and Max Acceleration

With frequency 5 Hz to 2000 Hz at sweep rate of 2 Oct/min. Multipoint maximal Control at armature top.

- 2.1 Plot response accelerations for all three axes at locations shown in Figure-1. (DAS)
- 2.2 Plot Control, Drive, Armature current, and Armature voltage (CS).

3. Resonance test (Post signature)

1g Constant control.

Frequency 5 Hz to 2000 Hz at 2 Oct/min. Control being at centre of armature.

- 3.1 Plot response accelerations for all three axes at locations shown in Figure-1. (DAS)
- 3.2 Plot Drive, O/P current, and O/P voltage.

4. Diaphragming and Cross axis response test

5g Constant control from 5 Hz to 2000 Hz with required slopes for Displacement and velocity, with sweep rate of 2 Oct/min.

Control at centre of armature.

4.1 Plot response accelerations for all three axes at locations shown in Figure-1.

4.2 Plot Drive, O/P current and O/P voltage

5. Noise measurement on armature top

With amplifier Set to 100% gain and zero input signal

5.1 Measure accelerometer output at the armature top for 5 Hz to 20 kHz analysis range.
(Expected level <0.2g)

6. Low g sine test

Constant input acceleration level of 0.2g Frequency 5 Hz to 2000 Hz at 2 Oct/min.

Control being at centre of armature.

6.1. Plot response accelerations for all three axes at locations shown in Figure-1.

6.2. Plot Drive, O/P current and O/P voltage.

7. Random rating test

20-100Hz: 6dB/Oct,

100-2000Hz: flat PSD to obtain the maximal acceleration

Multipoint maximal Control at armature top

7.1. Plot response accelerations for all three axes at locations shown in Figure-1.

7.2. Plot Drive, O/P current and O/P voltage.

8. Low g -rms random test

Flat PSD from 20 Hz to 2000 Hz 0.2 grms test level.

Control being at centre.

8.1. Plot response accelerations for all three axes at locations shown in Figure-1.

8.2. Plot Drive, O/P current and O/P voltage.

9. Resonance test (Post-signature)

1g Constant control.

Frequency 5 Hz to 2000 Hz at 2 Oct/min.

Control being at centre of armature.

9.1 Plot response accelerations for all three axes at locations shown in Figure-1.

9.2 Plot Drive, O/P current and O/P voltage.

10. Static load test

Load test value shall be mutually decided based on available test masses.

11. Wave form distortion tests

With input of 1g between 5 Hz to 100 Hz

The THD shall be $\leq 5\%$ between 5 Hz to 100 Hz

THD computation shall be carried as per ISO5344

Bare Table Load Test

1. Resonance test (Pre-signature)

1g Constant control.

Frequency 5 Hz to 2000 Hz at 2 Oct/min.

Control being at centre of armature.

1.1 Plot response accelerations for all three axes at locations shown in Figure-1.

1.2 Plot Drive, O/P current and O/P voltage.

2. Sine test

Typically, with 2 times weight of armature (supplier shall provide the mass)

Max displacement,

Max velocity

Acceleration to achieve max sine force rating of the shaker.

Multi point maximal Control

Frequency 5 Hz to 2000 Hz at 1 Oct/min. Plot Drive, O/P current and O/P voltage.

Check wave form distortion of accelerometer output and Amplifier output using Digital data acquisition system.

Acceleration limited to maximum force rating of shaker.

3. Random test

Typically, with 2 times weight of armature (supplier shall provide the mass)

20-100 Hz: 6 dB/Oct,

100 – 2000 Hz: flat PSD for full random force rating.

Multipoint maximal Control

3.1 Plot acceleration, Drive, O/P current and O/P voltage.

4. Endurance test

Shaker shall run continuously for 30 Minutes with the following specification.

Typically, with 2 times weight of armature (supplier shall provide the mass)

Maximum displacement,

Maximum velocity,

Acceleration limited to maximum force rating of shaker.

Multi point maximal Control

Frequency 5 Hz to 2000 Hz at 2 Oct/min.

4.1 Plot acceleration, Drive, O/P current and O/P voltage.

5. Resonance test (Post signature)

1g Constant control.

Frequency 5 Hz to 2000 Hz at 2 Oct/min.

Control being at center of armature

Accelerometer Locations: Figure-1

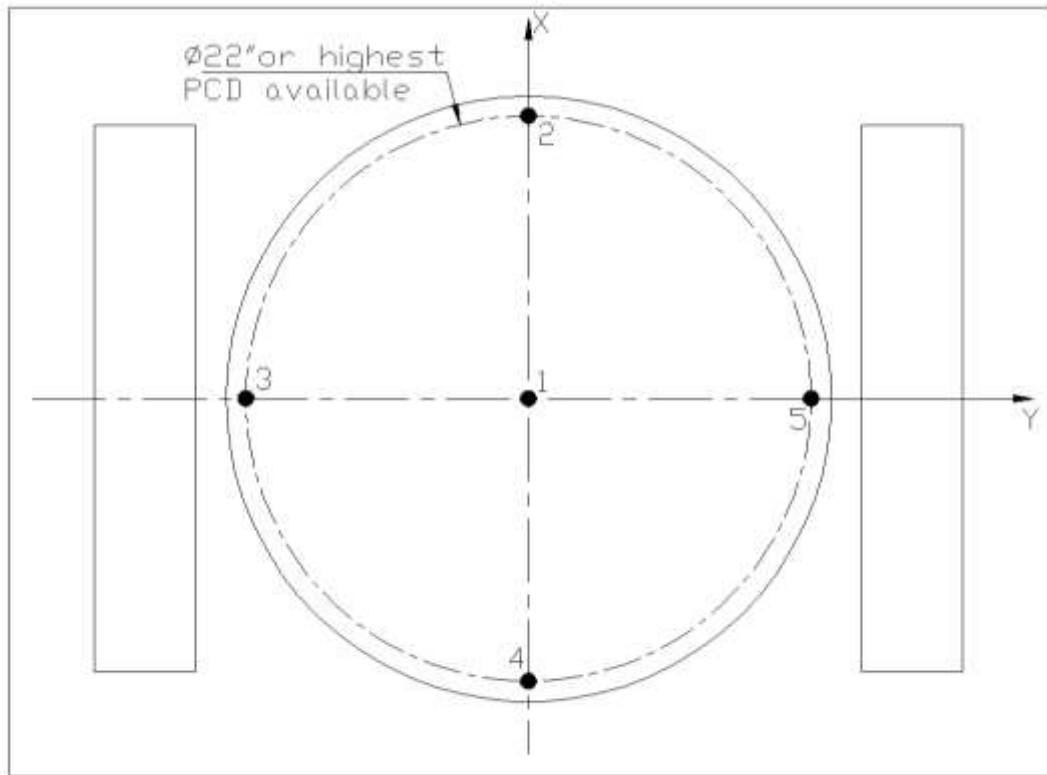

Armature accelerometer position

Dual Shaker System Configuration with quoted Control system

Externally Guided Head Expander - Bare Table

1. Resonance test (Pre-signature)

1g Constant control.

Frequency 5 Hz to 2000 Hz at 2 Oct/min.

Control at 2100 mm PCD.

- 1.1. Plot response accelerations for all three axes at locations shown in Figure-2.
- 1.2. Plot Drive, O/P current and O/P voltage.

2. Max displacement, Max Velocity and Max Acceleration (limited to force rating of the shaker)

With frequency 5 Hz to 2000 Hz at sweep rate of 2 oct/min.

Multipoint maximal Control at 2100 mm PCD

- 2.1 Plot response accelerations for all three axes at locations shown in Figure-2.
- 2.2 Plot Drive, O/P current and O/P voltage

3. Resonance test (Post-signature)

1g Constant control.

Frequency 5 Hz to 2000 Hz at 2 Oct/min.

Control at 2100 mm PCD.

- 3.1 Plot response accelerations for all three axes at locations shown in Figure-2.
- 3.2 Plot Drive, O/P current, and O/P voltage.

4 Diaphragming and Cross axis response test

5g Constant control from 5 Hz to 2000 Hz with required slopes for Displacement and velocity, with sweep rate of 2 Oct/min.

Multi point maximal Control at 2100 mm PCD.

- 4.1 Plot response accelerations for all three axes at locations shown in Figure-2.
- 4.2 Plot Drive, O/P current and O/P voltage.

5.0 Random rating test

(20-100 Hz: 6 dB/Oct,

100-2000Hz: flat PSD to obtain the max. rms acceleration)

Multi point maximal Control at 1700 mm PCD

5.1 Plot response accelerations for all three axes at locations shown in Figure-2.

5.2 Plot Drive, O/P current, and O/P voltage.

6.0 Resonance test (Post signature)

1g Constant control.

Frequency 5 Hz to 2000 Hz at 2 Oct/min.

Control at 2100 mm PCD.

6.1 Plot response accelerations for all three axes at locations shown in Figure-2.

6.2 Plot Drive, O/P current, and O/P voltage.

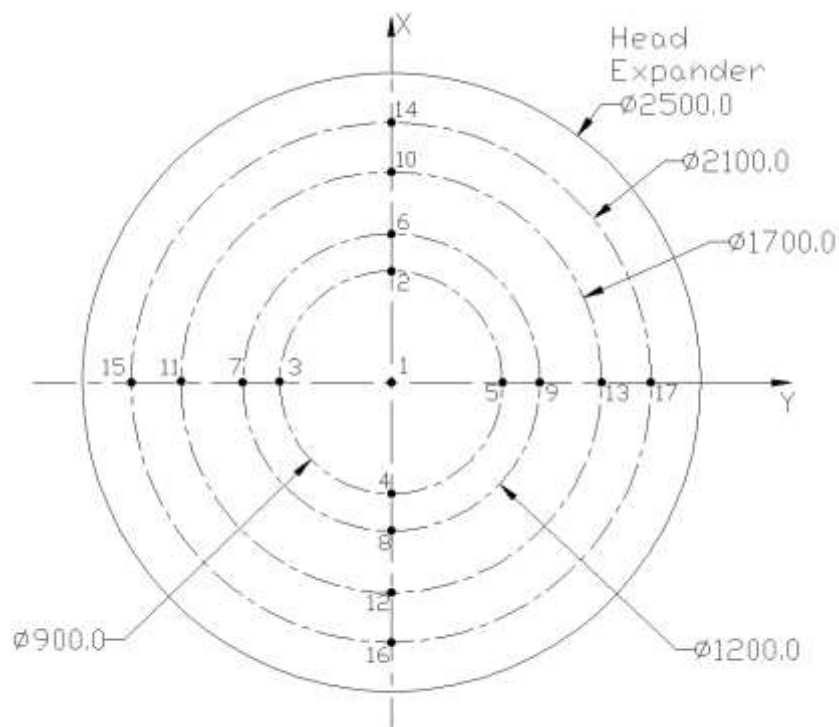

Head expander accelerometer position

FIGURE – 2 Head Expander Accelerometer Positions

2500 MM SLIP-TABLE

1. Resonance test (Pre-signature)

1g Constant control.

Frequency 5 Hz to 2000 Hz at 2 Oct/min.

Control at slip table end along shaker axis (10-32 heli-coil for accelerometer mounting provision to be provided).

- 1.1. Plot response accelerations for all three axes at locations shown in Figure-3.
- 1.2. Plot Drive, O/P current and O/P voltage.

2. Max displacement, Max Velocity and Max Acceleration (limited to maximum force rating of the shaker)

With frequency 5Hz to 2000 Hz at sweep rate of 2 Oct/min.

Multipoint maximal Control at end of the slip table

- 2.1 Plot response accelerations for all three axes at locations shown in Figure-3.
- 2.2 Plot Drive, O/P current and O/P voltage. Plot Drive, O/P current and O/P voltage.

3. Resonance test (Post-signature)

1g Constant control.

Frequency 5 Hz to 2000 Hz at 2 Oct/min.

Control at slip table end along shaker axis 10-32 helicoil for accelerometer mounting provision to be provided).

- 3.1 Plot response accelerations for all three axes at locations shown in Figure-3.
- 3.2 Plot Drive, O/P current and O/P voltage.

4. Cross axis response test

5g Constant control from 5 Hz to 2000 Hz with required slopes for Displacement and velocity, with sweep rate of 2 Oct/min.

Control at end of the slip table.

- 4.1. Plot response accelerations for all three axes at locations shown in Figure-3.
- 4.2. Plot Drive, O/P current, and O/P voltage.

5. Random rating test

(20-100Hz: 6dB/Oct, 100-2000 Hz: flat PSD to obtain the max rms acceleration)

Multipoint maximal Control at end of the slip table

5.1 Plot response accelerations for all three axes at locations shown in Figure-3.

5.2 Plot Drive, O/P current, and O/P voltage.

6. Resonance test (Post signature)

1g Constant control.

Frequency 5 Hz to 2000 Hz at 2 Oct/min.

Control at end of the slip table.

6.1 Plot response accelerations for all three axes at locations shown in Figure-3.

6.2 Plot Drive, O/P current, and O/P voltage.

FIGURE – 3 Slip Table Accelerometer Positions

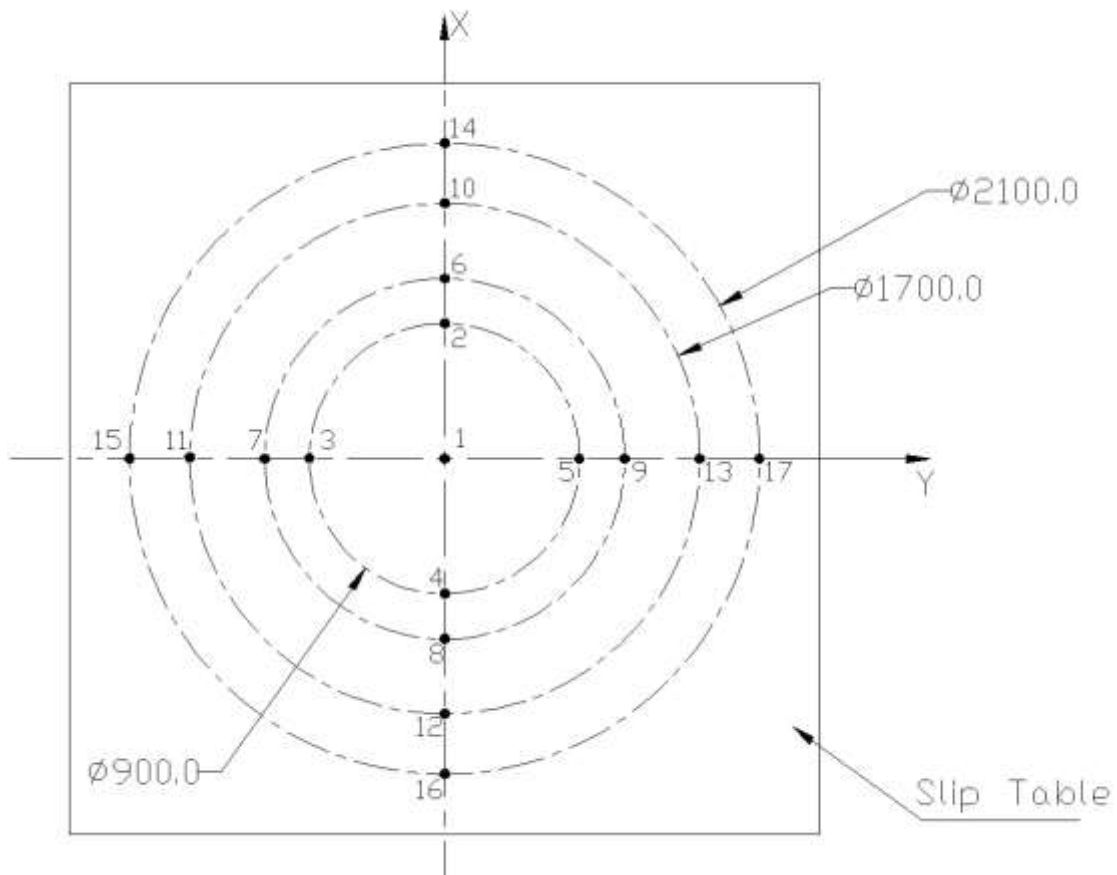

POWERAMPLIFIER

1. Noise measurement

Bare table

With amplifier Set to 100% gain and zero input signal

Measurement of output voltage and current with input shorted and amplifier set to 100% gain

2. Wave form distortion tests

2.1. TEST-a

With an acceleration of 1g on armature bare table top between 5Hz to 100Hz, record the Output Voltage and Current wave forms.

2.2. TEST-b

Record output voltage and current wave forms for

Maximum displacement sine dwell

Maximum velocity sine dwell

Maximum acceleration sine dwell

3. Shaker system interlocks

Over travel limit by test Cooling unit flow switch Temperature switch Field power supply Emergency Abort switches

Annexure-3

Site Acceptance Test (SAT) Plan ITPF, Tumkur after installation

Shaker system along with the Control System, Data Acquisition System and associated instrumentation elements delivered as part of this tender should be fully integrated and tested as per the following test requirements. All accelerations channels should be connected both to control system and data acquisition system.

Shaker and amplifier should be tested individually (as single shaker system configuration) as well as in dual mode configuration along with dual head expander and 2.5 m slip table. **Push-push shall be demonstrated with fully integrated control system, data acquisition system at ITPF, Tumkur.**

Typical Control System Settings

Sine:

- Frequency range: As per the test plan
- Test Level: As per the test plan
- Control strategy: Maximal control in case of multi point control
- Compression factor: Typical 100 % / 4
- Alarm & Abort: +/- 3 & +/- 6
- Sweep rate: As per the test plan
- Control estimator: BBRMS / RMS
- Start rate or start up time: 10 dB / sec or 2 sec
- COLA: to be available for data acquisition system

Random:

- Frequency range: As per the test plan
- Test Level: As per the test plan
- Control strategy: Maximal control in case of multi point control
- DOF: 120
- Alarm & Abort: +/- 3 & +/- 6
- Test duration: As per the test plan
- Resolution: 5 Hz
- Processing Window: Hanning

- Averages: 16

DAS Settings for Acquisition:

- Sampling rate: for sine 12.8 KHz, 6400 Hz for random
- Processing Window: Hanning
- Averages: 16
- COLA: to be recorded

**Individual Shaker System Configuration with delivered Control system and Data Acquisition System
(All the Test to be carried on the both the shaker system independently)**

BARETABLE

1. Resonance test (Pre-signature)

1g Constant control.

Frequency: 5 Hz to 2000 Hz at 2 Oct/min. Control at centre of armature.

- 1.1. Plot response accelerations for all three axes at locations shown in Figure-1. (DAS)
- 1.2. Plot Control, Drive, Armature current, and Armature voltage (CS).

2. Max displacement, Max Velocity and Max Acceleration

With frequency 5 Hz to 2000 Hz at sweep rate of 2 Oct/min.

Multi-point maximal Control at armature top

- 2.1. Plot response accelerations for all three axes at locations shown in Figure-1. (DAS)
- 2.2. Plot Control, Drive, Armature current, and Armature voltage (CS).

3. Resonance test (Post signature)

1g Constant control.

Frequency 5 Hz to 2000 Hz at 2 Oct/min. Control at centre of armature.

- 3.1 Plot response accelerations for all three axes at locations shown in Figure-1. (DAS)
- 3.2 Plot Drive, O/P current, and O/P voltage.

4. Diaphragming and Cross axis response test

5g Constant control from 5 Hz to 2000 Hz with required slopes for Displacement and velocity, with sweep rate of 2 Oct/min.

Control being at centre of armature.

- 4.1. Plot response accelerations for all three axes at locations shown in Figure-1.
- 4.2. Plot Drive, O/P current and O/P voltage

5. Noise measurement on armature top

With amplifier Set to 100% gain and zero input signal

- 6.1 Measure accelerometer output at the armature top for 5 Hz to 12.8 kHz analysis range. (Expected level < 0.2g)

6. Static Load Test

With suitable interface plate and Test Mass.
Test Mass \geq 1200 kg (Mass will be supplied by LPSCB)
Demonstration of auto-centering under static load condition.

7. Low g sine test

Constant input acceleration level of 0.2g Frequency 5 Hz to 2000 Hz at 2 Oct/min.

Control being at centre of armature.

- 7.1. Plot response accelerations for all three axes at locations shown in Figure-1.
- 7.2. Plot Drive, O/P current and O/P voltage.

8. Random rating test

20-100Hz: 6dB/Oct,

100-2000Hz: flat PSD to obtain the max rms acceleration

Multi-point maximal Control at armature top

- 8.1. Plot response accelerations for all three axes at locations shown in Figure-1.
- 8.2. Plot Drive, O/P current and O/P voltage.

9. Low g -rms random test

Flat PSD from 20 Hz to 2000 Hz 0.2 grms test level.

Control at centre.

- 9.1. Plot response accelerations for all three axes at locations shown in Figure-1.
- 9.2. Plot Drive, O/P current and O/P voltage.

10. Resonance test (Post signature)

1g Constant control.

Frequency 5Hz to 2000Hz at 2 Oct/min.

Control being at centre of armature.

10.1. Plot response accelerations for all three axes at locations shown in Figure-1.

10.2. Plot Drive, O/P current and O/P voltage.

11. Wave form distortion tests

With input of 1g between 5 Hz to 100 Hz

THD shall be $\leq 5\%$ between 5Hz–100Hz

THD computation shall be carried as per ISO5344

Bare Table Load Test

1 Resonance test (Pre signature)

1g Constant control.

Frequency 5 Hz to 2000 Hz at 2 Oct/min.

Control at centre of armature.

1.1 Plot response accelerations for all three axes at locations shown in Figure-1.

1.2 Plot Drive, O/P current and O/P voltage.

2 Sine test

With 2 times weight of armature (supplier shall provide the mass)

Max displacement,

Max velocity

Acceleration to achieve max sine force rating of the shaker.

Multipoint maximal Control

Frequency 5 Hz to 2000 Hz at 2 Oct/min.

Plot Drive, O/P current and O/P voltage.

Check wave form distortion of accelerometer output and Amplifier output using Digital data acquisition system.

Acceleration limited to maximum force rating of shaker.

3 Random test

With mass 2 times weight of armature

20-100Hz: 6dB/Oct,

100-2000Hz: flat PSD for full random force rating.

Multi-point maximal Control

15.1 Plot acceleration, Drive, O/P current and O/P voltage.

4 Endurance test

Duration shall be less than 30 minutes but will be decided by LPSCB.

Typically, with mass of 2 times weight of armature

Maximum displacement,

Maximum velocity,

Acceleration limited to maximum force rating of shaker.

Multi-point maximal Control

Frequency 5 Hz to 2000Hz at 2 Oct/min.

4.1 Plot acceleration, Drive, O/P current and O/P voltage.

5 Resonance test (Post-signature)

1g Constant control.

Frequency 5 Hz to 2000 Hz at 2 Oct/min.

Control being at center of armature

Accelerometer Locations: Figure -1

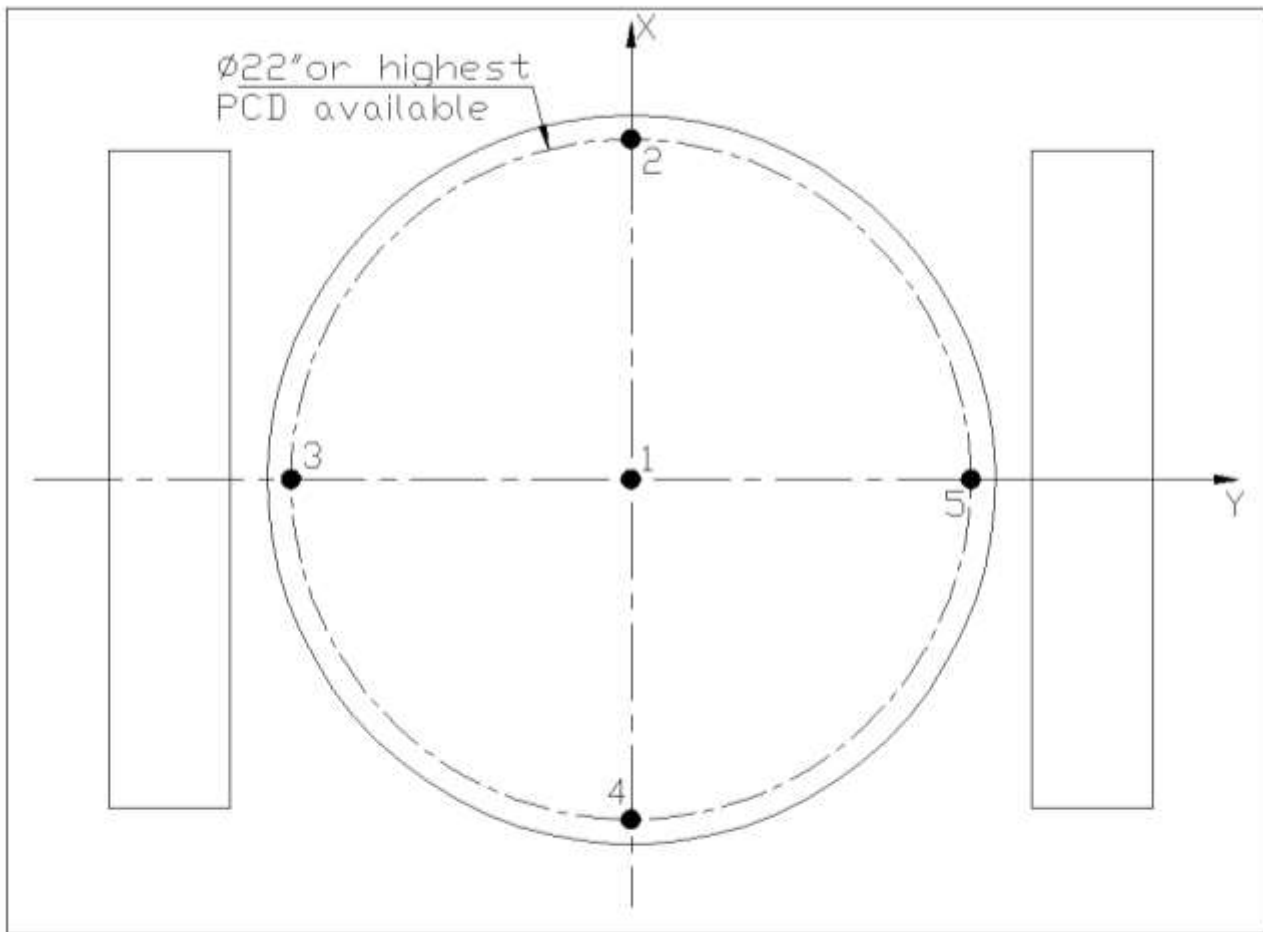

Armature accelerometer position

Dual Shaker System Configuration with delivered Control system and Data Acquisition System

Externally Guided Head Expander - Bare Table

1. Resonance test (Pre-signature)

1g Constant control.

Frequency 5 Hz to 2000 Hz at 2 Oct/min.

Control at 2100 mm PCD.

- 1.1. Plot response accelerations for all three axes at locations shown in Figure-2.
- 1.2. Plot Drive, O/P current and O/P voltage.

2. Max displacement, Max Velocity and Max Acceleration (limited to force rating of the shaker)

With frequency 5 Hz to 2000 Hz at sweep rate of 2 oct/min.

Multi-point maximal Control at 2100 mm PCD

- 2.1 Plot response accelerations for all three axes at locations shown in Figure-2.
- 2.2 Plot Drive, O/P current and O/P voltage

3. Static Load Test

With suitable interface plate and Test Mass.

Test Mass \geq 10000 kg (Mass will be supplied by LPSCB)

Demonstration of auto-centering under static load condition.

4. Resonance test (Post signature)

1g Constant control.

Frequency 5 Hz to 2000 Hz at 2 Oct/min.

Control at 2100 mm PCD.

- 4.1 Plot response accelerations for all three axes at locations shown in Figure-2.
- 4.2 Plot Drive, O/P current, and O/P voltage.

5. Diaphragming and Cross axis response test

5g Constant control from 5 Hz to 2000 Hz with required slopes for Displacement and velocity, with sweep rate of 2 Oct/min.

Multi point maximal Control at 2100 mm PCD.

5.1 Plot response accelerations for all three axes at locations shown in Figure-2.

5.2 Plot Drive, O/P current and O/P voltage.

6. Random rating test

(20-100Hz: 6dB/Oct,

100-2000Hz: flat PSD to obtain the max rms acceleration)

Multi-point maximal Control at 2100 mm PCD

6.1 Plot response accelerations for all three axes at locations shown in Figure-2.

6.2 Plot Drive, O/P current, and O/P voltage.

7. Resonance test (Post signature)

1g Constant control.

Frequency 5 Hz to 2000 Hz at 2 Oct/min.

Control at 2100 mm PCD.

7.1 Plot response accelerations for all three axes at locations shown in Figure-2.

7.2 Plot Drive, O/P current, and O/P voltage.

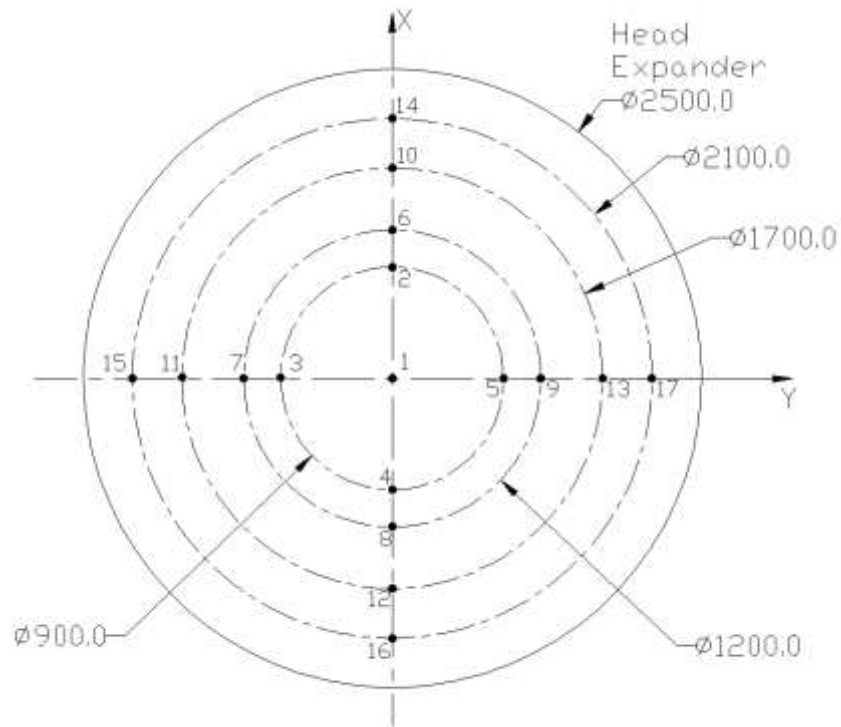

Head expander accelerometer position

FIGURE – 2 Head Expander Accelerometer Positions

2500 MM SLIP-TABLE

1. Resonance test (Pre-signature)

1g Constant control.

Frequency 5 Hz to 2000 Hz at 2 Oct/min.

Control at slip table end along shaker axis (10-32 helicoil for accelerometer mounting provision to be provided).

- 1.1. Plot response accelerations for all three axes at locations shown in Figure-3.
- 1.2. Plot Drive, O/P current and O/P voltage.

2. Max displacement, Max Velocity and Max Acceleration (limited to maximum force rating of the shaker)

With frequency 5 Hz to 2000 Hz at sweep rate of 2 Oct/min.

Multi-point maximal control at end of the slip table

2.1 Plot response accelerations for all three axes at locations shown in Figure-3.

2.2 Plot Drive, O/P current and O/P voltage. Plot Drive, O/P current and O/P voltage.

3. Static Load Test

With suitable interface plate and Test Mass.

Test Mass \geq 10,000 kg (Mass will be supplied by LPSCB)

4. Resonance test (Post signature)

1g Constant control.

Frequency 5 Hz to 2000 Hz at 2 Oct/min.

Control at slip table end along shaker axis (10-32 helicoil for accelerometer mounting provision to be provided).

4.1. Plot response accelerations for all three axes at locations shown in Figure-3.

4.2. Plot Drive, O/P current and O/P voltage.

5. Cross axis response test

5g Constant control from 5 Hz to 2000 Hz with required slopes for Displacement and velocity, with sweep rate of 2 Oct/min.

Control at end of the slip table.

5.1 Plot response accelerations for all three axes at locations shown in Figure-3.

5.2 Plot Drive, O/P current, and O/P voltage.

6. Random rating test

(20-100Hz: 6dB/Oct, 100-2000 Hz: flat PSD to obtain the max rms acceleration)

Multi point maximal Control at end of the slip table

6.1 Plot response accelerations for all three axes at locations shown in Figure-3.

6.2 Plot Drive, O/P current, and O/P voltage.

7. Resonance test (Post signature)

1g Constant control.

Frequency 5 Hz to 2000 Hz at 2 Oct/min.

Control at end of the slip table.

7.1 Plot response accelerations for all three axes at locations shown in Figure-3.

7.2 Plot Drive, O/P current, and O/P voltage.

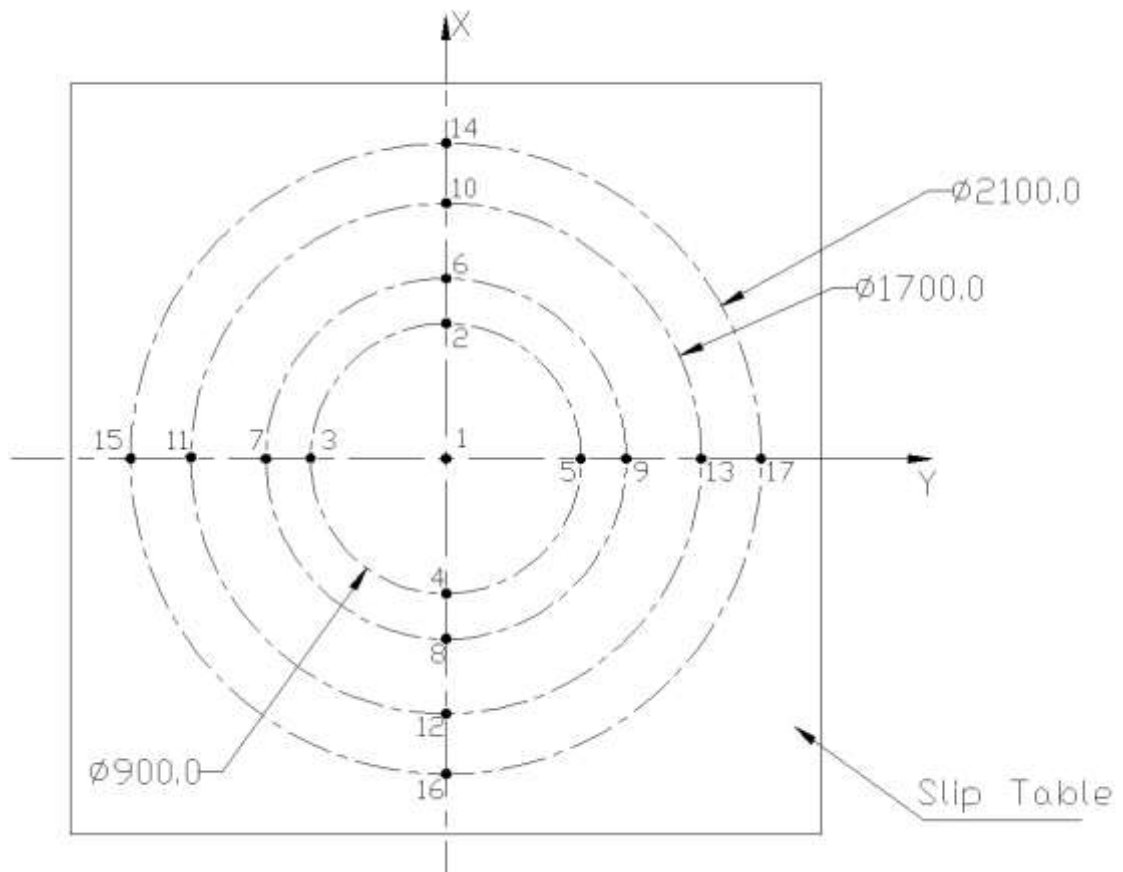

FIGURE – 3 Slip Table Accelerometer Positions

POWERAMPLIFIER

1. Noise measurement

Bare table

With amplifier Set to 100% gain and zero input signal

Measurement of output voltage and current with input shorted and amplifier set to 100% gain.

2. Wave form distortion tests

2.1. TEST-a

With an acceleration of 1g on armature bare table top between 5 Hz to 100 Hz, record the Output Voltage and Current wave forms.

2.2. TEST-b

Record output voltage and current wave forms for

Maximum displacement sine dwell

Maximum velocity sine dwell

Maximum acceleration sine dwell

3. Shaker system interlocks

Over travel limit by test Cooling unit flow switch Temperature switch Field power supply

Emergency Abort switches

Annexure – 4: Technical Compliance Statement

Technical Compliance statement

(To be submitted along with Part-I of the offer)

Note: Merely stating, “comply” does not constitute sufficient information. Exact numerical values are to be specified wherever applicable. Specified technical data should be supported by product catalogues, manuals, test procedures, and test plots etc. In case of insufficient technical data, the quote will be summarily rejected without seeking any clarifications.

Description	Compliance
<p>1. Introduction</p> <p>1.1. Electro-dynamic Shaker is required to be used for carrying out Vibration testing of Propellant Tanks and its subsystem for satellite. The system should consist of 20 Ton Shaker system (2 Nos), Power amplifier (2 Nos), DSCIS (1 no), Slip Table (1 No) and Head Expander (1 Nos). In dual mode operation, both the shakers should be coupled to the slip table in push-push mode. Adequate test article Interfacing, static load capacity and dynamic force and moment capabilities shall be built into the system for the purpose as detailed in the specification. The system will be housed in a clean environment and hence sufficient care should be taken to ensure that the shaker system does not produce contaminants.</p> <p>1.2. Vendor shall provide a techno-commercial presentation at LPSC, Bengaluru after as a part of technical evaluation of offers. The technical presentation shall include the following.</p> <ul style="list-style-type: none">1.2.1 Compliance matrix for the quoted system.1.2.2 Heritage for the quoted system.1.2.3 Technical schematic and details of the quoted system.1.2.4 Test results/data of the quoted system. <p>Vendors who have submitted their offers and not attending the techno-commercial presentation within 15 days of intimation from LPSC, Bangalore will not be considered.</p> <p>1.3. Supplier should manufacture, supply, deliver to the site, install, commission the shaker system and provide test results as per the acceptance test plan. The major subsystems of the Shaker system shall comprise of</p> <ul style="list-style-type: none">1.3.1 Electrodynamic shaker with common base slip-table1.3.2 Guided Head Expander.1.3.3 Digital switching power amplifier with Matching Transformer1.3.4 Field Power Supply & Cooling Unit.1.3.5 Base Plate and Reinforcement Structure	

Sl. No.	Description	Compliance
2.	Specific requirement	
2.1.	<p>Supplier's experience</p> <p>The supplier should have experience in supplying Electrodynamic shakers of 20,000 kgf force capacity or higher capacity to aerospace industries or institutions.</p>	
2.2.	<p>Heritage of the offered system</p> <p>The supplier should have supplied at least one number of Dual Shaker System in the preceding 5 years with same configuration as detailed in the specifications to the aerospace industries or institutions. Test results and performance plots of such systems are to be provided. The supplied shaker system should have completed at least 12 months of satisfactory performance.</p> <p>The supplier should provide the details of the dual shaker system supplied with contract / purchase order copies, model number, year of supply and copy of installation /acceptance report along with the details of the such customers including name of the organization, end user division/group and contact details of the end user.</p> <p>It should be noted that this will be one of the criteria for evaluation of the offer for technical suitability. The offers without this information will be rejected without any further reference.</p>	
2.3.	<p>Local service support</p> <p>Supplier should have service center or authorized service center with trained service engineers in India. Service center address contact person details, phone/fax numbers, email should be provided along with the offer.</p>	
2.4.	<p>Original manufacturer</p> <p>The quote should be only from the original manufacturer of the system. In case if the offer is from the authorized representative, authorization certificate from the original manufacturer should be provided along with the quote.</p>	
2.5.	<p>Certificate of origin</p> <p>Certificate of origin should include the following,</p> <ol style="list-style-type: none"> 1. Year of manufacturing 2. Country of manufacturing 	

Sl. No.	Description		Compliance
3.	Specification for single Shaker		
3.1	General features	Electrodynamic Shaker on a common base with slip-table having bolt down to foundation plate and air isolation configurations.	
3.2	Quantity	2 Nos	
3.3	Type	Water cooled	
3.4	Sine Force Rating (Peak)	$\geq 20,000$ Kgf	
3.5	Random Force Rating (Rms)	$\geq 17,000$ Kgf	
3.6	Maximum Half sine bump force	$\geq 40,000$ Kgf	
3.7	Static Load capacity	≥ 1200 Kg on bare table	
3.8	Useful frequency range	5 Hz to 2000Hz	
3.9	Body resonance frequency	≤ 3 Hz	
3.10	Max. Acceleration Sine Random Half Sine Shock	≥ 75 g pk (bare table) ≥ 55 g rms (20-100Hz: 6dB/Oct; 100-2000Hz: Flat PSD) ≥ 50 g peak, 10 ms	
3.11	Max. Velocity	≥ 1.8 m/sec for sine	
3.12	Max. Displacement	≥ 50.8 mm (2") Peak- Peak	
3.13	Axial stiffness	< 100 N/mm	
3.14	Cross axial Stiffness	$\geq 24,000$ N/mm	
3.15	Rotational Stiffness	≥ 500 KN m/rad	
3.16	Offset Moment	≥ 2.8 KNm	

Sl. No.	Description		Compliance
3.17	Minimum possible test level	3.17.1 ≤ 0.2 g peak swept sine test from 5 Hz to 2000 Hz in Broad Band RMS (BBRMS) measurement mode with (12.8 kHz) bandwidth for control channel. 3.17.2 Control location on armature top 3.17.3 With power amplifier 100% gain	
3.18	Armature Diameter	≤ 760 mm Nominal	
3.19	Armature mass	≤ 250 kg	
3.20	Fundamental Armature Resonance	≥ 1250 Hz	
3.21	Armature Cross axis	Excluding Resonance Peaks: 5 Hz – 500 Hz: < 12%; 500 Hz – 1000 Hz: < 15%; Including resonance Peaks: 5 Hz – 100 Hz: < 12%; 100 Hz – 200 Hz: < 35%; 200 Hz – 1000 Hz: < 50%; 1000 Hz – 2000 Hz: < 80%; Measured on higher PCD of the armature without load.	
3.22	Armature Suspension	Armature shall be supported with suitable suspension mechanisms such as flexures, rolling strut assemblies, etc. The necessary drawings shall be provided.	
3.23	Armature guidance	Armature shall be internally guided with suitable Hydrostatic journal bearings to provide lateral movement restraint.	
3.24	Armature over travel interlock	Armature over travel should be sensed using non-contact type optical sensor/scale. Armature over travel interlock should trip the power amplifier.	

Sl. No.	Description		Compliance
3.25	Armature position display	3.25.1 Armature position should be sensed using non-contact type optical sensor/scale 3.25.2 Digital or LED bar graph display of the armature position should be provided simultaneously near the shaker as well as at the remote-control panel at control room approximately 50 meters away from shaker bay.	
3.26	Shaker body position display	3.26.1 Shaker body position should be sensed using non-contact type optical sensor/scale 3.26.2 Digital or LED bar graph display of the armature position should be provided simultaneously near the shaker as well as at the remote-control panel at control room approximately 50 meters away from shaker bay.	
3.27	Raised inserts for armature table (Typical)	These interface holes should be provided with UNC-M12 stainless steel inserts. 3.27.1 One number of M12 insert at center (if feasible) 3.27.2 8 numbers of M12 inserts at 8" PCD 3.27.3 8 numbers of M12 inserts at 16" PCD 3.27.4 8 numbers of M12 inserts at 22" PCD 3.27.5 8 numbers of M12 inserts at 28" PCD (only if armature diameter \geq 750 mm)	
3.28	Auto centering of armature	3.28.1 Auto-centering of the armature for the rated static load should be provided. This should be achieved with non-contact type optical sensing and pneumatic servo-based armature position control system.	

Sl. No.	Description	Compliance	
		3.28.2 Manual over ride provision should also be provided. 3.28.3 Display of armature position monitoring shall be provided.	
3.29	Adaptor plate– 1(1 no.) <ul style="list-style-type: none"> • Flatness: ≤ 0.1mm per meter • Surface finish: 3-triangle finish or better (roughness average ≤ 1.6micron) • Parallelism: 0.2mm per meter or better 	50 mm thick magnesium alloy (AZ31) circular plate with following specimen interface and suitable with armature table insert pattern of Sl.No.3.26 . Inserts are UNC-M12 / M8 stainless steel inserts flushed with plate surface. 3.29.1 One hole at center – M12 Insert (Applicable only if the armature table does not have insert at center) 3.29.2 6” PCD with 8 Holes at 45o – M8 inserts 3.29.3 8” PCD with 8 Holes at 45o – M12 inserts 3.29.4 12” PCD with 8 Holes at 45o – M8 inserts 3.29.5 16” PCD with 8 Holes at 45o – M12 inserts 3.29.6 22” PCD with 8 Holes at 45o – M12 inserts 3.29.7 28” PCD with 8 Holes at 45o – M12inserts (only for armature diameter of >750 mm)	
3.30	Armature mechanical locking and interlock	3.30.1 Mechanical locking of armature with shaker body when the shaker is in idle condition to be provided. 3.30.2 Mechanical locks should have interlock with power amplifier.	
3.31	Armature Lock-out Mechanism with interlock	3.31.1 Provision to mechanically lock-out the Armature when not in operation shall be provided to support the entire moving mass including the Static load around 1200kg.	

Sl. No.	Description	Compliance	
		3.31.2 Interlock Switches for the locking mechanism shall be provided. 3.31.3 Interlock shall be provided with Cooling Unit/Power Amplifier.	
3.32	Geared shaker rotation	3.32.1 Rotating mechanism with reduction gear for assembling the shaker to the slip table. 3.32.2 Electrical cables, water hoses and Hydraulic hoses are to be properly guided and secured during shaker rotation.	
3.33	Shaker body suspension	Shaker body suspended with respect to trunnion should have locking provision in vertical and horizontal position.	
3.34	Shaker vertical / horizontal tilt switch	Shaker vertical / horizontal tilt switch interlocked with slip table hydraulic supply and power amplifier should be provided.	
3.35	Trunnion guidance	The shaker unit should be provided with a trunnion and guidance system with Pneumatic isolation system. <ul style="list-style-type: none"> ● The vibrator shall be trunnion mounted, which allows the thrust axis to be rotated from the vertical to the horizontal by means of a motor or manual drive coupled to a gearbox; ● The vibrator body shall be provided with guidance system. ● The vibrator body should be isolated from the ground by means of air mounts of appropriate capacity; 	
3.36	Shaker Cooling unit.	3.36.1 The shaker should be provided with an external de-ionized /distilled water-based cooling unit which in-turn is cooled by raw water. 3.36.2 The cooling unit shall be of suitable capacity for cooling of the shaker system. Rating and technical details of the cooling system shall be provided along with technical quote.	

Sl. No.	Description	Compliance
		<p>3.36.3 Cooling unit shall incorporate digital display of Armature inlet temperature, Armature outlet temperature and Field Coil temperatures.</p> <p>3.36.4 The cooling unit should incorporate interlocks for raw water temperature, raw water flow, armature coil temperature, field coil temperature, shaker body temperature, etc.</p> <p>Note: Chiller unit of suitable capacity to be provided.</p>
3.37	Liquid detection sensor for shaker body	Shaker body should be fitted with a Liquid detection sensor to detect any internal leaks from armature coils, and field coils and hydro static bearings.
3.38	Scavenging pump for shaker hydraulic oil.	<p>3.38.1 Hydraulic oil return line should be fitted with a scavenging pump of appropriate capacity.</p> <p>3.38.2 Shaker combo base to be installed below the floor level based on site condition.</p>
3.39	Hydraulic power supply unit	<p>3.39.1 A suitable Hydraulic power supply unit with oil pressure interlock, required oil hoses and electrical cables are to be provided, for a length of 30 m minimum.</p> <p>3.39.2 Electrical Mains Supply: 3 phase, 415V AC +/- 5%,50 Hz.</p>
3.40	Operating Environment	<p>3.39.1 Temperature: 15°C to 35°C</p> <p>3.39.2 Relative Humidity: 20% to 80%</p>
3.41	Shaker Handling provision for movement through Crane	<p>3.41.1 Provision shall be provided for mounting of eye-bolts of suitable diameter for movement of the shaker using overhead crane.</p> <p>3.41.2 Accessories for handling, lifting and movement like, suitable</p>

Sl. No.	Description		Compliance
		handling Eyebolts, etc., shall be also be supplied.	
3.42	<p>Slip Table</p> <p>a) Shaker system with trunnion support and slip-table should be mounted on to a common Steel structure (seismic base structure with steel base plate) in a suitable manner for providing permanent alignment of Shaker with the Slip table.</p> <p>b) The shaker and slip table shall be designed to support detaching of the Shaker system and slip table whenever required.</p> <p>c) The Slip Table should have appropriate mounting interface for connecting the two numbers of shaker system for Twin shaker operation in push-push mode.</p> <p>d) The shaker unit along with Slip Table should be isolated from floor using Air mounts of appropriate capacity, to ensure that the vibration at full load is not transmitted to the floor.</p> <p>e) The provision shall exist to by-pass and bolt-down the Air mount of the shaker/Slip table directly to the seismic foundation using the steel base plates.</p> <p>f) The common base shall be provided with Lateral restraint mounts.</p> <p>g) Slip plate shall be supported by granite base with oil film and guided by high pressure hydrostatic journal bearings.</p> <p>h) The maximum number of bearings required to be populated around the centre to get the specified moments (ref. spec. 4.7) and to minimize cross-axis response (ref. spec. 4.10).</p> <p>i) Supplier shall submit the fabrication drawing of the slip plate for LPSC, Bengaluru approval with respect to bearing configuration and insert pattern before proceeding with fabrication.</p>		
3.42.1	Slip Table dimension	2500mm (L) X2500 (W) X 70mm (T)	
3.42.2	Slip plate material	Magnesium Alloy (AZ31) Tool plate	
3.42.3	Flatness:	≤ 0.1mm per meter	
3.42.4	Surface finish:	3-triangle finish or better	

Sl. No.	Description		Compliance
		(Roughness average \leq 1.6micron)	
3.42.5	Parallelism:	0.2 mm per meter or better	
3.42.6	Overturning Moment (Supplier to provide the bearing configuration as part of technical offer)	Pitch	> 650 kN-m
		Roll	>700 kN-m
		Yaw	>150 kN-m
3.42.7	Number of high-pressure hydrostatic journal bearings (Supplier to provide the bearing configuration as part of technical offer)	<p>3.42.7.1 26 Nos. minimum</p> <p>3.42.7.2 Complete dimensional and performance details for the different type of bearings used shall be provided as part of technical offer.</p> <p>3.42.7.3 Optimum bearing configuration to meet the moment capability as per Sl. No. 4.7 and cross axis response as per Sl. No. 4.10 to be provided. In case of the proposed bearing configuration requires installation of less number of bearings, the remaining bearings are to be supplied as spares.</p> <p>3.42.7.4 The Final bearing configuration will be approved by LPSC (B) at the time of order.</p>	
3.42.8	Bare table resonance frequency	>500 Hz	
3.42.9	Cross axis responses	Excluding Resonance Peaks: 5 Hz – 500 Hz: < 12%; 500 Hz – 1000 Hz: < 15%;	

Sl. No.	Description		Compliance
		<p>Including resonance Peaks: 5 Hz – 100 Hz: < 12%; 100 Hz – 200 Hz: < 35%; 200 Hz – 1000 Hz: < 50%; 1000 Hz – 2000 Hz: < 80%;</p> <p>Measured on higher PCD of the slip-table without load as per FAT measurement plan.</p>	
3.42.10	Maximum static payload capacity	> 22,000 kg	
3.42.11	Displacement	≥ 40 mm peak to peak (bare table)	
3.42.12	Combined Useful Frequency range of shaker with slip-table	5 to 2000 Hz.	
3.42.13	Mounting hole pattern	<p>3.42.13.1 100 mm X 100 mm grid – M12 inserts</p> <p>3.42.13.2 900 mm PCD – 16 holes– M12 inserts</p> <p>3.42.13.3 1200 mm PCD – 32 holes– M12 inserts</p> <p>3.42.13.4 1700 mm PCD - 96 Holes – M12 inserts</p> <p>3.42.13.5 2100 mm PCD - 96 Holes – M12 inserts</p> <ul style="list-style-type: none"> • All Inserts are UNC-M12 stainless steel inserts flushed with slip-plate surface. • Inserts should have locking pins apart from self-locking inserts. • The bearing mounting holes shall be optimised to • avoid interference with any PCD/Grid insert pattern as far as possible. • In case of interference of 100mm × 100mm grid inserts with PCD inserts or bearing holes, the interfering grid inserts can be deleted to accommodate the PCD inserts or bearing holes. 	

Sl. No.	Description		Compliance
3.42.14	Accelerometer mounting	10-32 UNF heli-coil at an interval of 0.5mtrs at from slip table centre. (multiple points)	
3.42.15	Driver bar	<p>3.42.15.1 Type: Tension bolt type</p> <p>3.42.15.2 All welded construction.</p> <p>3.42.15.3 Material: Magnesium Alloy (AZ31)</p> <p>3.42.15.4 Handling provision for lifting/ mounting/movement (eyebolt handling provision)</p>	
3.42.16	Hydraulic power supply unit	<p>3.42.16.1 A suitable Hydraulic power supply unit with oil pressure interlock, required oil hoses and electrical cables are to be provided.</p> <p>3.42.16.2 Electrical Mains Supply: 3 phase, 415V AC +5%, 50 Hz.</p> <p>3.42.16.3 Scavenging pump of appropriate capacity to be provided.</p> <p>3.42.16.4 Shaker combo base to be installed below the floor level based on site condition.</p>	
3.42.17	Slip plate over travel switch	Slip plate over travel switch to be interlocked to power amplifier	
3.42.18	Slip plate surface temperature	Maximum stabilized slip plate temperature should not exceed 45°C under the laboratory ambient of 25°C.	
3.42.19	Operating Environment	<p>3.42.19.1 Temperature: 15°C to 35°C</p> <p>3.42.19.2 Relative Humidity: 20% to 80%</p>	
3.43	Guided Head Expander		

Sl. No.	Description		Compliance
3.43.1	Type	3.43.1.1 Externally Guided head Expander. 3.43.1.2 Guided Head Expander should be designed such that it couples both Shakers in vertical configuration for dual mode operation. 3.43.1.3 Cross section schematic diagram to be provided showing the details of external guidance and construction details. 3.43.1.4 Suitable flexure to be provided with tuned mass dampers.	
3.43.2	Table Diameter (Typical)	2500 mm	
3.43.3	Moving mass (Typical)	<1500 kg (excluding armature)	
3.43.4	Moving element material	Magnesium alloy	
3.43.5	Flatness:	≤ 0.1 mm per meter	
3.43.6	Surface finish:	3-triangle finish or better (roughness average ≤ 1.6 micron)	
3.43.7	Locking Mechanism with interlock	3.43.7.1 Provision to mechanically lock the moving element when not in operation. 3.43.7.2 Interlock switches for locking mechanism. 3.43.7.3 Interlocked with power amplifier/ cooling unit	
3.43.8	Displacement	≥ 40 mm Peak to Peak (bare table)	
3.43.9	Hydraulic power supply	3.43.9.1 A dedicated suitable Hydraulic power supply unit with oil pressure interlock, required oil hoses and	

Sl. No.	Description		Compliance
		<p>electrical cables are to be provided.</p> <p>3.43.9.2 Electrical Mains Supply: 3 phase, 415V AC +5%, 50 Hz.</p> <p>3.43.9.3 Scavenging pump of appropriate capacity to be provided.</p>	
3.43.10	Bare table resonance frequency	≥250 Hz	
3.43.11	Static Load Capacity	≥ 10000 Kg	
3.43.12	Mounting hole pattern	<p>3.43.12.1 100mm × 100mm grid – M12 inserts</p> <p>3.43.12.2 900mm PCD – 16 holes- M12 inserts</p> <p>3.43.12.3 1200 mm PCD–32 holes - M12 inserts</p> <p>3.43.12.4 1700 mm PCD- 96 Holes– M12 inserts</p> <p>3.43.12.5 2100 mm PCD - 96 Holes – M12 inserts</p> <p>All Inserts are UNC-M12 stainless steel inserts flushed with slip-plate surface.</p> <p>Inserts should have locking pins apart from self-locking inserts.</p> <p>The bearing mounting holes shall be optimised to avoid interference with any PCD/Grid insert pattern as far as possible.</p> <p>In case of interference of 100mm × 100mm grid inserts with PCD inserts or bearing holes, the interfering grid inserts can be deleted to accommodate the PCD inserts or bearing holes.</p>	
3.43.13	Operating Environment	<p>3.43.13.1 Temperature: 15°C to 35°C</p> <p>3.43.13.2 Relative Humidity: 20% to 80%</p>	

Sl. No.	Description		Compliance
3.44	Power Amplifier 2 Nos (1 no for each shaker)		
3.44.1	Type	<p>3.44.1.1Pulse Width Modulated (PWM) switching type, Class-D amplifier (Digitally modulated power amplifier).</p> <p>3.44.1.2Modular in construction</p> <p>3.44.1.3Scalable architecture.</p> <p>3.44.1.4Provision to separately supply power to armature during head expander mounting is preferred.</p>	
3.44.2	Amplifier Capacity	<p>Total capacity shall be suitable to the rated capacity of the shaker.</p> <p>Number of power modules required for rated capacity to be provided.</p>	
3.44.3	Individual power module capacity	<p>$\geq 5\text{kVA}$ and should not be more than 15kVA</p> <p>Specify Maximum sine current rating and Maximum voltage rating.</p>	
3.44.4	Frequency Response	<p>Full power: 10Hz to 2000 Hz</p> <p>Half power (-3dB): 3 kHz</p>	
3.44.5	Efficiency	$\geq 90\%$	
3.44.6	Switching Frequency	$\geq 100\text{ kHz}$	
3.44.7	Total Harmonic Distortion (THD) when connected with shaker	<p>With an acceleration of 1 g on armature bare table top between 5 Hz to 100 Hz and with 2 kHz measurement bandwidth, the THD should be $\leq 5\%$.</p> <p>THD shall be computed as per ISO 5344 standard.</p>	
3.44.8	Hum and Noise of amplifier output	$\leq 0.05\text{ V rms}$. With input shorted and maximum gain.	
3.44.9	Peak current handling	Approximately three times or more than the continuous sine current rating for a period of 100 ms	
3.44.10	Soft Start and Stop	Soft Start and Stop to avoid transients due to switching ON and OFF of the amplifier	

Sl. No.	Description		Compliance
3.44.11	Connections provision	Heavy-duty terminal blocks for connecting vibrator armature cables.	
3.44.12	Cable length between amplifier and shaker	30 meters typical for meeting the 100% force rating of the shaker system. (Final length will be given at the time of ordering)	
3.44.13	Line Filter (Power)	Line filter (RFI filter) to be incorporated to meet the emission levels specified by European Union (EU) directive 2004/108/CE (previously 89/336/EEC) or equivalent standard. The total system should comply with EU directive 2004/108/CE or equivalent standard.	
3.44.14	Signal Inputs	3.44.14.1 1 Vrms for 100Vrms output. 3.44.14.2 Differential input compatible with Standard Vibration Controllers	
3.44.15	Output Voltage	Should be compatible with the Shaker	
3.44.16	Input Impedance	$\geq 10k\Omega$	
3.44.17	Power amplifier acoustic noise level	≤ 90 dBA at 1 m distance	
3.44.18	Power module protection for power blackout	The power devices / modules should be protected from failure during abrupt mains power blackout during operation.	
3.44.19	Electrical Mains Supply	3 Phase, 415 Volts AC $\pm 5\%$ 50 Hz {Tapping on input of transformer required: 380V, 400V, 415V, 440V, 460V}	
3.44.20	Control and Protection Circuits	Microprocessor based system	
3.44.21	Controls to be provided ON/OFF controls from amplifier local and remote panels for the following: a) Field power supply		

Sl. No.	Description	Compliance
	b) Cooling unit c) Hydraulic oil supply unit d) Amplifier Gain	
3.44.22	Interlocks to be provided a) Shaker over travel b) Armature coil over temperature c) Field coil over temperature d) Shaker vertical/Horizontal interlock e) Low voltage supplies fault f) HT Under voltage/Over voltage g) Module over current / Fault h) Power amplifier over load i) Field failure j) Cooling unit fault k) Hydraulic oil pressure fault l) Slip Table over travel m) Emergency abort n) External trip	
3.44.23	Monitoring outputs a) Scaled down output for armature voltage b) Scaled down output for armature current	
3.44.24	Digital display of temperature in cooling unit a) Armature inlet temperature b) Armature outlet temperature c) Field coil inlet temperature d) Field coil outlet temperature e) Distilled / de-ionised water temperature in tank	
3.44.25	Metering a) Amplifier output voltage b) Amplifier output current	
3.44.26	Indications Amplifier Interlocks and status display at local and remote panels	

Sl. No.	Description		Compliance
	a) Auxiliary power supplies ON b) Mains supply Low/ High voltage c) Low voltage supplies fault d) HT Under voltage/Over voltage e) Output over current f) Output over voltage g) Vibrator cooling fault h) Vibrator over travel i) Field failure		
3.44.27	Remote Control Panel (50 m distance from amplifier) a) Auxiliary ON/OFF control b) Amplifier ON/OFF control c) Gain control d) All Indications e) Metering display of output voltage f) Metering display of output current		
3.44.28	Overload settings	Provision at front panel or remote unit for limit setting of amplifier output current and output voltage.	
3.44.29	Cooling	Forced air cooled	
3.44.30	Construction	3.44.30.1 Construction should be such that physical addition or removal of power modules should be easily carried out and whole amplifier system should be mounted on integrated 19" racks with wheels and jacks 3.44.30.2 Openings should be sealed to make it rodent free.	
3.44.31	Operating environment	3.44.31.1 Temperature: 15°C to 35°C	

Sl. No.	Description		Compliance
		3.44.31.2 Relative Humidity: 20% to 80%	
3.44.32	Run-time		
3.45	Dual Shaker Control Interface System (DSCIS) – 1 No.		
3.45.1	Dual shaker shall be operated in PUSH-PUSH configuration		
3.45.2	Shakers should be configured in such a way that single mode operation shall be enabled as and when required.		
3.45.3	Necessary safety interlocks for specimen protection shall be incorporated.		
3.46	Field Power Supply (FPS) - 2 Nos.		
3.46.1	Type	Standalone or built-in with amplifier	
3.46.2	Power Rating	Should be suitable to deliver the full rated load, with a provision to vary the output.	
3.46.3	Economy mode and Full field mode	Automatic change over for a) Reduced field current when power amplifier is disabled b) Full field when power amplifier is enabled	
3.46.4	Stray Magnetic field	≤ 1.5 mT at 150mm above armature table	
3.46.5	Field protection	The field power supply should be protected against short circuit and should be provided with freewheeling diodes.	
3.46.6	Interlocks	Should be provided with suitable interlock with amplifier for auto start and field failure indication.	
3.46.7	Electrical Mains Supply	3 Phase, 415 Volts AC ± 5% 50 Hz {Tapping on input of transformer required: 380V, 400V, 415V, 440V, 460V}	
3.46.8	Line Filter (Power)	Line filter (RFI filter) to be incorporated to meet the emission levels specified by	

Sl. No.	Description		Compliance
		European Union (EU) directive 2004/108/CE (previously 89/336/EEC) or equivalent standard. The system should comply with EU directive 2004/108/CE or equivalent standard.	
3.46.9	Metering (Digital)	a) Field current b) Field voltage	
3.46.10	Cable length between FPS and shaker	30 meters typical. (Final length will be given at the time of ordering)	
3.46.11	Cooling	Forced air cooled	
3.46.12	Construction	Standard 19" racks with wheels and jacks. Openings should be sealed to make it rodent free.	
3.46.13	Operating environment	Temperature: 15°C to 35°C Relative Humidity: 20% to 80%	
3.47	Other requirements		
3.47.1	Emergency abort switches	Emergency abort switches at shaker, FPS, Power amplifier, slip-table and at Remote control panel	
3.47.2	Cables between Shaker Amplifier	Connecting Copper cable length between Filed power supply and Amplifier to the shaker is typically 30 meters (Final length will be given at the time of ordering)	
3.47.3	Quality of Finish	All equipment's should have good finish with anti-corrosive protection	
3.47.4	Duty Cycle	The Shaker/Amplifier/Slip Table/ Guided Head Expander should be rated for One-hour continuous operation at full rated output force.	
3.47.5	Alignment and maintenance tool kit	Tool kit comprising of the necessary tools is to be supplied for alignment and maintenance of the shaker system	

Sl. No.	Description		Compliance
		Detailed list of tools of the tool kit should be given.	
3.47.6	List of deliverables	List of deliverables to meet the functional requirements should be given along with the Techno commercial quote (Part-I of the offer).	
3.47.7	Utility requirements: Supplier should provide details of the utilities required for operation of the shaker system like power requirements, water flow and pressure requirements, compressed air requirements, etc.		

Digital Vibration Control System

Sl. No.	Description		Compliance
Specification for Digital Vibration Control System			
1.	<p>Introduction</p> <p>The 24 channel Digital Vibration Control System (with provision for future expansion up to 64 channels) should be capable of operating dual shaker system in PUSH-PUSH configuration for carrying out sine, random and shock testing of satellite propellant tanks and subsystems.</p> <p style="text-align: center;">Digital vibration control system should be any one of the following make and model which were qualified by LPSC(B) / URSC</p> <p>a) Abacus Signal Star- Vector from M/s Data Physics (or)</p> <p>b) Scadas Lab from M/s Siemens PLM</p> <p>c) M+p control system</p>		
2.	Instrumentation Front End		
2.1.	Number of Input Channels	Minimum of 24 channels with provision for future expansion up to 64 channels	
2.2.	No of outputs	Minimum of four from independent Digital to Analog hardware	
2.3.	Input and output connectivity	<p>2.3.1 BNC Connector.</p> <p>2.3.2 If BNC connectors are provided on a breakout box, these breakout boxes should be mounted on a 19” rack panel for ensuring rigid support.</p>	
2.4.	Calibration/validation	<p>2.4.1 It should be possible to carry out ON-SITE Instrumentation front-end calibration without the need of support/intervention from the vendor.</p> <p>2.4.2 Any H/W & S/W accessories for the same shall be provided as part of deliverables.</p>	

Sl. No.	Description		Compliance
		<p>2.4.3 Offset removal and gain linearity check for all the input/output channels should be provided.</p> <p>2.4.4 In case if any channel fails in calibration, the calibration process should continue skipping that particular channel. It should be possible to isolate/disable the failed channel in further calibration steps.</p>	
3	<p>COMPUTER</p> <p>Vendor has to ensure that the computer platform chosen is sufficient to meet overall functional requirement of control system</p>		
3.1.	Operating System	Microsoft Windows-10 Professional 64-bit or better or Linux with support.	
3.2.	Platform	<p>3.2.1 Intel i7-4790 3.6 GHz (8 cores) Processor or Better</p> <p>3.2.2 Suitable high-speed system bus or better.</p> <p>3.2.3 Intel/OEM Chipset on OEM motherboard compatible with quoted processor.</p>	
3.3.	RAM	<p>3.3.1 Minimum 32 GB DDR4 RAM or better.</p> <p>3.3.2 System shall support memory extension up to 64 GB.</p> <p>3.3.3 Minimum Two DIMM slots shall be free after configuring all the required memory modules. Specify total and occupied DIMM slots.</p> <p>3.3.4 Vendor shall configure memory DIMM as per the best practices specified by processor OEM for the best and balanced performance.</p>	
3.4.	Hard disk	3.4.1 1 set (2 numbers) of 2TB (min.) or better HDD with RAID 1 (disk mirroring) feature for OS & application software.	

Sl. No.	Description		Compliance
		<p>3.4.2 1 set (2 numbers) of 2TB (min.) or better HDD with RAID 1 (disk mirroring) feature for data storage.</p> <p>3.4.3 The hard disk shall be with SATA interface; e-SATA/NL-SAS interfaces are preferred.</p> <p>3.4.4 The hard disk shall be divided into two logical drives one for OS/application software and another for data.</p>	
3.5.	Monitor	<p>3.5.1 Two numbers of 28 inch or higher Size, full HD LED monitors with 1920 x 1080P resolution or better.</p> <p>3.5.2 These monitors shall be connected in Dual Mode configuration.</p> <p>3.5.3 Monitor shall be of Non-Touch type.</p>	
3.6.	DVD-R/W Drive	16X or better DVD Super Multi double-layer drive with DVD and CD read-write capability.	
3.7.	I/O ports	<p>3.7.1 USB 3.0 or better – minimum 2 nos.</p> <p>3.7.2 USB ports to connect mouse, Keyboard, Printer and Scanner shall be provided separately.</p>	
3.8.	Pointing Device	USB Optical Scroll mouse.	
3.9.	Keyboard	Space saver ergonomic keyboard with 104 keys or better.	
3.10.	Networking	<p>3.10.1 Minimum 1Gbps Ethernet LAN port to connect to Instrumentation front end.</p> <p>3.10.2 One Additional 1Gbps Ethernet LAN port to connect computer to LAN network.</p> <p>3.10.3 The network port shall be RJ45 connector.</p>	

Sl. No.	Description		Compliance
3.11.	Additional Display Port	1 No.; Apart from connecting the computer to display monitors, shall have provision to simultaneously connect the computer to standard high-resolution external LED display or external projector.	
3.12.	Graphics	<p>3.12.1 Integrated dual graphics supporting FHD resolution. Video interface: Display Port, HDMI</p> <p>3.12.2 Graphics card shall support simultaneously three displays in the following configuration</p> <ul style="list-style-type: none"> • 2 monitors in Dual Mode configuration. • 1 for external projector or high-resolution external LED display with HDMI interfaces to display the content of one of the dual monitors. 	
3.13.	Display Projection	<p>3.13.1 The system shall be able to interface to the projector system or on LED display of the master screen with master/slave monitors enabled for viewing.</p> <p>3.13.2 The vendor shall clearly bring out any issues in interfacing the control system to the projector or LED display.</p> <p>3.13.3 Quote shall be given separately if any additional hardware required for connecting the projector or LED display.</p> <p>3.13.4 The required accessories to connect different type of projector shall be provided.</p>	
3.14.	Licensing and recovery of OS	The OS shall be licensed with license key. OS Recovery and Driver DVD to be supplied.	

Sl. No.	Description		Compliance
3.15.	Additional network switch	One 16/24 port 1Gbps unmanaged network switch shall be mounted in the rack provided with the quoted system.	
3.16.	Removable Hard disk	2 nos. of 2TB removable HDD with USB interface for data portability.	
3.17.	Printer and scanner	<p>Color Printer</p> <p>3.17.1 1 No. of Color Laser Jet Printer with scan function, with built in USB& Network port, with automatic duplex (double side) printing capability and with printing speed of greater than 30 PPM.</p> <p>3.17.1.1 Paper size: A4</p> <p>3.17.1.2 Duty cycle: 1 Lakh pages per month or more</p> <p>3.17.1.3 One of the input tray capacities shall be at least 500 pages.</p> <p>3.17.1.4 Replacement black cartridges shall support more than 11K pages capacity.</p> <p>3.17.1.5 The necessary driver software for the printer shall be provided.</p>	
4	ELECTRICAL SUPPLY		
4.1	Voltage	All equipment should support for 220 Volts AC	
4.2	Frequency	50 Hz \pm 5%	
4.3	Phase	Single	
4.4	OPERATING ENVIRONMENT		
4.5	Operating temperature	15°C to 35°C	
4.6	Relative Humidity	20% to 80%	
5	SOFTWARE		

Sl. No.	Description		Compliance
5.1	General Provisions	<ul style="list-style-type: none"> • Software features listed in this section of 5.1 should be provided to all the software modules defined in sections 6, 7, and 8. • The software should cater for Control, Acquisition and Analysis for Swept Sine, Dwell, Resonance Dwell, Random, Classical Shock and SRS testing of Spacecraft Propellant Tank and its subsystems using Electro-Dynamic Shakers. • Transient Data reproduction of previously recorded signal or signal generated using in-built software on Shaker shall also be provided. 	
5.2	Channels Setup Parameters	<p>5.2.1 Sensitivity definable in terms of mV/EU</p> <p>5.2.2 Channel Naming</p> <p>5.2.3 Input coupling – AC, DC, IEPE</p> <p>5.2.4 Option to include/exclude individual channels in loop check</p> <p>5.2.5 Option to activate/inactivate automatic nulling of the offset before test beginning should be provided</p> <p>5.2.6 Option to set a channel as control/measurement channel.</p> <p>5.2.7 Importing of channel definition file between sine, random, shock, and SRS test definitions</p> <p>5.2.8 Storing channel setup data in file for future recall.</p> <p>5.2.9 Printing channel setup values.</p>	
5.3	Data display options	<p>5.3.1 Tiled display with data displayed one next to the other.</p> <p>5.3.2 Data of multiple channels of single and multiple tests should be displayable in single and multiple windows, with up to 4 channels per window and up to 4 windows displayable at a time to enable comparison between two test data.</p> <p>5.3.3 Over-plotting of the selected channels preferably between different tests.</p>	

Sl. No.	Description		Compliance
		5.3.4 Over-plotting of all the channels between different tests. 5.3.5 Hard copy printing provision for all the above display plots.	
5.4	Cursor Operations	5.4.1 Provision to list selected points of the graph along with the graph 5.4.2 Zooming of a selected band in the graph should be possible. 5.4.3 Automatic peak picking in the selected range of frequency and amplitude. Provision for manual peak picking to add additional peaks along with automatically picked peaks. 5.4.4 Manual & Automatic setting of the range for X and Y-axes. 5.4.5 Option to set Linear/logarithmic scale for X and Y-axes. 5.4.6 Option to enable/disable grid lines.	
5.5	Batch Printing	Batch printing of selected channels with automatic peak picking in selected range of frequency and amplitude	
5.6	Report Generation	5.6.1 Facility should be present to save the display plots in PDF format as well as Microsoft word or equivalent format for report generation purpose. 5.6.2 It should be possible to export all plots of a test at once to MS word or equivalent with optional peak picking for each of the plots. 5.6.3 Necessary software required for the above should be supplied along with the system.	
5.7	Documentation and Data Storage	5.7.1 Output Spectra of all channels, drive, reference, tolerance, and notching & abort limits. 5.7.2 Provision for entering two lines of legend for each test. 5.7.3 Message Log for each test	
5.8	Data exchange	Import and export support for	

Sl. No.	Description		Compliance
		5.8.1 Universal File Format- data set 58/58B & other data sets 5.8.2 Spread sheet format. 5.8.3 ASCII data file and MATLAB - Export only.	
5.9	Control system dynamic range	Better than 90dB	
5.10	Safety Features	5.10.1 Loop check to detect input anomalies before test with following features 5.10.2 User selectable maximum output drive voltage 5.10.3 User selectable noise threshold in mV RMS. 5.10.4 Measurement of loop gain, noise, etc., should be possible. 5.10.5 User selectable threshold for control signal loss.	
5.11	Control features during testing	5.11.1 ABORT, Start and Resume functions. 5.11.2 Start up from low level to full level in user defined level steps/time. 5.11.3 Provision for Manual or Auto start selection from initial test level to full level. 5.11.4 On line message/status display of test activities	
5.12	Security Features	5.12.1 User Level Access Control 5.12.2 Test data access control	
5.13	Instrumentation Front-end Calibration	Provision for on-site Instrumentation Front-end Calibration should be provided with Calibration Software and associated Hardware/accessories for field calibration as per specification 2.1.17	
5.14	Time domain data display	5.14.1 Provision should exist for time domain data display of all channels for the purpose of verification prior to start of test.	
5.15	Post test data review	5.15.1 Data review of last conducted test 5.15.2 Data review of stored tests	

Sl. No.	Description		Compliance
5.16	Hardcopy Output	5.16.1 Test definition details 5.16.2 Test Plots 5.16.3 Post Test messages	
5.17	Software Licensing	5.17.1 Vendor should clearly spell out the possible options available, like dongle-based licensing, computer MAC-id based licensing, etc. 5.17.2 Dongle based license is preferred.	
6	Random Testing: Random testing involves excitation of the test specimen with a stationary random signal of a given frequency spectrum and monitoring of the responses at various points.		
6.1	Frequency Range	5 Hz to 10KHz.	
6.2	Number of spectral lines	User selectable from 100 to 3200	
6.3	Degrees of Freedom of control	10 to 1000	
6.4	Pretest Levels	User definable from – 40 to 0 dB	
6.5	Startup/Shutdown rate	User definable. Typically, between 0 to 24dB/Sec Or Equivalent	
6.6	Output signal	6.6.1 True Gaussian with minimum 3-sigma control 6.6.2 Provision for Drive clipping with the following user definable parameter 6.6.3 3.2.7.2.1 Sigma level between 2.5 to 6 OR 6.6.4 Drive voltage limit: 0.1 V to 10 V	
6.7	Control Strategy	6.7.1 Single Channel 6.7.2 Multiple Channel 6.7.3 Average 6.7.4 Maximum 6.7.5 Minimum	
6.8	Limiting / Abort Setting	6.8.1 Automatic limiting of output signal to enable 6.8.2 response limitation of specified monitoring 6.8.3 Channels.	

Sl. No.	Description		Compliance
		6.8.4 Definition of up to 23 notching / limiting / Abort profiles. 6.8.5 Any of the 24 channels, other than control, should be definable as limiting / Abort channel with individual profile.	
6.9	Control loop Equalization	Equalization within 2 control loops	
6.10	Control amplitude accuracy	± 1 dB	
6.11	Averaging type	Linear, exponential	
6.12	Windowing	Hanning, Keiser Bessel, rectangular, exponential, etc.	
6.13	Reference spectrum definition	6.13.1 Number of Break points or segments > 50 6.13.2 Definition of any segment by slope or amplitude 6.13.3 Scaling of the spectrum by defining overall RMS level 6.13.4 Individual alarm/abort level definition for each segment. 6.13.5 Importing of reference spectrum from a stored file.	
6.14	Alarm/Abort	6.14.1 User definable number of spectral lines for alarm/abort activation. 6.14.2 RMS Alarm/Abort definition in terms of dB. 6.14.3 User definable pretest level, at which alarm/abort definitions are activated.	
6.15	Display and Analysis features	6.15.1 Power Spectral Density function of a given channel. 6.15.2 Transmissibility - Amplitude & phase transfer function of a channel with respect to another channel. 6.15.3 Along with the display of the plot of the selected channel, following statistical parameters to be displayed. 6.15.4 Test time. 6.15.5 gRMS,	

Sl. No.	Description		Compliance
		6.15.6 Maximum and minimum amplitude with frequency.	
7	Sine Testing		
7.1	Test Types	7.1.1 Swept Sine Test 7.1.2 Sine Frequency dwell 7.1.3 Tracked Resonance dwell – Phase dwelling	
7.2	Frequency Range	1Hz to 10KHz	
7.3	Control Strategy	7.3.1 Single Channel 7.3.2 Multiple Channel, 7.3.3 Average 7.3.4 Maximum 7.3.5 Minimum	
7.4	Sweep definition	In terms of 7.4.1 Number of sweeps 7.4.2 Duration	
7.5	Direction of sweeping	7.5.1 Up 7.5.2 Down 7.5.3 Up Only (in multiple sweeps definition)	
7.6	Sweep rate	7.6.1 Log – 0.1 to 10 Oct/Min 7.6.2 Linear – 0.1 to 100 Hz/Min	
7.7	Drive signal	User definable maximum drive voltage from 0.1V to 10Vpk.	
7.8	Drive Compression	7.8.1 Fixed – Definable between 1 to 300 dB / Sec, OR 7.8.2 User definable for different range of frequencies (segment) - between 1% to 100% OR Equivalent	
7.9	Sweep Accuracy	Better than + 3%	
7.10	Control amplitude accuracy	+1dB	
7.11	Frequency Accuracy	Equal to or better than +/-0.5 % of test frequency.	

Sl. No.	Description		Compliance
7.12	Harmonic distortion	Better than 60dB at full scale output.	
7.13	Reference spectrum definition	7.13.1 Number of segments > 50 7.13.2 Definition of any segment by 7.13.3 Acceleration 7.13.4 Velocity 7.13.5 Displacement 7.13.6 Sloped acceleration 7.13.7 Individual Alarm & Abort level definition for each segment. 7.13.8 Importing of reference spectrum from a stored file.	
7.14	Startup/Shutdown rate	7.14.1 User definable. Typically, between 0 to 24dB/Sec OR Equivalent. 7.14.2 Level increment greater than 0dB in 0.1dB steps.	
7.15	Tracking filter	7.15.1 Proportional Bandwidth (constant percentage) OR Equivalent. 7.15.2 Fixed Bandwidth OR Equivalent.	
7.16	Notching / Limiting / Abort	7.16.1 Automatic notching of output signal to enable response limitation of specified monitoring channels. 7.16.2 Definition of up to 23 Notching/ Abort profiles. 7.16.3 Any of the 24 channels, other than control, should be definable as Notching/Limiting/ Abort channel with individual profile.	
7.17	Display and Analysis features	7.17.1 Response function measurement for each channel 7.17.2 Fundamental (filtered) 7.17.3 RMS (unfiltered) 7.17.4 Frequency Response Function (Transmissibility) of each channel w.r.t defined reference channel. 7.17.5 Fundamental (filtered) 7.17.6 RMS (unfiltered)	

Sl. No.	Description		Compliance
		7.17.7 Phase response, computed with respect to the filtered response, of the channel.	
7.18	Definitions specific to Dwell, Resonance dwell tests	7.18.1 Provision should exist for multiple Dwell frequency definition within a single test 7.18.2 Dwell duration, 7.18.3 Dwell range, 7.18.4 Dwell frequency, 7.18.5 Dwell phase, 7.18.6 Dwell level, 7.18.7 Dwell mode – manual OR automatic.	
8	Shock Testing	The shock testing involves simulating both Classical and SRS, acquiring the transient response and performing the analyses that include SRS (Shock Response Spectrum) analysis and mathematical manipulations that are listed below.	
8.1	Classical Shock		
8.2	Pulse types	8.2.1 Half Sine 8.2.2 Initial and Terminal Peak Saw tooth 8.2.3 Triangle	
8.3	Pulse duration	0.5 mSec to 2 Sec	
8.4	Pulse Amplitude	1g to 5000g	
8.5	Pre and Post Pulse	Definable in Percentage or Peak g	
8.6	Alarm/Abort	Alarm/Abort tolerances in terms of peak error defined as percentage of maximum amplitude – range 1% to 100%	
8.7	Number of Pulses	1 to 100	
8.8	Duration between Pulses	1Sec to 10 Sec	
8.9	Output polarity	Positive or Negative	

Sl. No.	Description		Compliance
8.10	Output Drive signal	User definable maximum drive voltage from 0.1V to 10Vpk.	
8.11	Equalization of Pulses	8.11.1 Manual 8.11.2 Automatic	
8.12	Classical Shock SRS Analysis parameters	8.12.1 SRS analysis of measurement channels should be possible with classical shock test module with 8.12.2 User definable 1/nth octave SRS analysis where n ranges from 1 to 24, 8.12.3 User definable damping ranging from 0.1% to 99%, 8.12.4 User definable analysis frequency range up to 10KHz. 8.12.5 SRS Analysis. 8.12.6 Primary Positive 8.12.7 Primary Negative 8.12.8 Primary Maximax, 8.12.9 Residual and Composite SRS.	
8.13	SRS Synthesis and analysis		
8.14	SRS Reference spectrum definition	8.14.1 Number of Break points or segments should be greater than 50 8.14.2 Definition of any segment by slope or amplitude 8.14.3 Individual tolerance band definition for each segment. 8.14.4 Importing of reference spectrum from a stored file.	
8.15	Synthesis frequency range	25 to 10,000 Hz.	
8.16	Synthesis amplitude range	1 to 10,000 g	
8.17	SRS generation modes	8.17.1 Wavelet synthesis 8.17.2 Damped sinusoids synthesis	
8.18	Channels Setup	8.18.1 In Addition to 3.1.2 above 8.18.2 Provision for selecting sample rate multiplier or sampling frequency 8.18.3 Time duration of the record,	

Sl. No.	Description		Compliance
		8.18.4 Type of triggering.	
8.19	Alarm/Abort	8.19.1 Alarm/Abort tolerances in terms of peak error defined as percentage of maximum amplitude – range 1% to 100%	
8.20	Drive signal	8.20.1 User definable maximum drive voltage from 0.1V to 10Vpk.	
8.21	SRS analysis of Time domain Analysis of Time Domain Signal	<p>The following parameters should be user selectable for the purpose of Acquisition and Analysis</p> <p>8.21.1 User definable analysis frequency range up to 10KHz.</p> <p>8.21.2 User definable 1/nth octave SRS analysis where ‘n’ ranges from 1 to 24,</p> <p>8.21.3 User definable damping ranging from 0.1% to 99%,</p> <p>8.21.4 SRS /all and Composite SRS.</p>	
8.22	PC Projection	<p>8.22.1 The system should be able to interface to the projector system projecting the master screen with master/slave monitors enabled for viewing.</p> <p>8.22.2 The vendor should clearly bring out any issues in interfacing the control system the projector.</p> <p>8.22.3 Quote should be given separately if any additional system are required for connecting the projector.</p>	

Vibration Data Acquisition System

Sl. No.	Vibration Data Acquisition System		Compliance
1.	<p>Introduction</p> <p>The Vibration Data Acquisition System will be used for acquiring and performing analysis of vibration data obtained during Vibration Testing of satellite propulsion subsystems</p> <p>The system is required to support a minimum of 48 channels of voltage and acceleration with provision for further expansion. Both software and hardware are required to be highly modular in structure to render the operation and maintenance easier. The modularity is required for easy scalability of the system for future requirements.</p> <p>Digital Data Acquisition system should be any one of the following make and model which were qualified by LPSC(B) / URSC</p> <p style="margin-left: 40px;">1.2.1 Scadas from M/s Siemens PLM (or)</p> <p style="margin-left: 40px;">1.2.2 Vib-runner from M/s M+P (or)</p> <p style="margin-left: 40px;">1.2.3 Abacus Signal Star-Vector from M/s Data Physics.</p>		
2.	Hardware - Instrumentation Front End		
	Features	Range/value	Compliance
2.1.	Number of Input Channels	Minimum of 48 channels with provision for future expansion up to 96 channels	
2.2.	input/output connectivity to instrumentation front end	<p>2.2.1 BNC Connector.</p> <p>2.2.2 If BNC connectors are provided on a breakout box, these breakout boxes should be mounted on a 19" rack panel for ensuring rigid support.</p>	
2.3.	Interface to Computer	High speed connectivity such as Ethernet or Firewire between the instrumentation front end and the computer. The connectivity should support the high data rate emanating from 100KHz sampling rate, 24-bit ADC and 48 channels (resulting in transfer rate of 19.2 MB/Sec or better)	

Sl. No.	Vibration Data Acquisition System		Compliance
2.4.	Calibration	<p>2.4.1 It should be possible to carry out ON-SITE Instrumentation front-end calibration without the need of support/intervention from the vendor.</p> <p>2.4.2 Any H/W & S/W accessories for the same shall be provided along with the system.</p> <p>2.4.3 Offset removal and gain linearity adjustment for all the input/output channels should be provided.</p> <p>2.4.4 In case if any channel fails in calibration, the calibration process should continue skipping that particular channel. It should be possible to isolate/disable the failed channel in further calibration steps.</p>	
3.	COMPUTER: Vendor has to ensure that the computer platform chosen is sufficient to meet overall functional requirement of control system		
3.1	Operating System	Microsoft Windows-10 Professional 64-bit or better or Linux with support.	
3.2	Platform	<p>3.2.1 Intel i7-4790 3.6 GHz (8 cores) Processor or Better</p> <p>3.2.2 Suitable high-speed system bus or better.</p> <p>3.2.3 Intel/OEM Chipset on OEM motherboard compatible with quoted processor.</p>	
3.3	RAM	<p>3.3.1 Minimum 32 GB DDR4 RAM or better.</p> <p>3.3.2 System shall support memory extension up to 64 GB.</p> <p>3.3.3 Minimum Two DIMM slots shall be free after configuring all the required memory modules. Specify total and occupied DIMM slots.</p> <p>3.3.4 Vendor shall configure memory DIMM as per the best practices specified by processor OEM for the best and balanced performance.</p>	
3.4	Hard disk	<p>3.4.1 1 set (2 numbers) of 2TB (min.) or better HDD with RAID 1 (disk mirroring) feature for OS & application software.</p> <p>3.4.2 1 set (2 numbers) of 2TB (min.) or better</p> <p>3.4.3 HDD with RAID 1 (disk mirroring) feature for data storage.</p> <p>3.4.4 The hard disk shall be with SATA interface; e-SATA/NL-SAS interfaces are preferred.</p>	

Sl. No.	Vibration Data Acquisition System		Compliance
3.5	Monitor	One 24" full HD LED monitor with 1920 x 1080 resolution or better.	
3.6	DVD-R/W Drive	16X or better DVD Super Multi double-layer drive with DVD and CD read-write capability.	
3.7	I/O ports	<p>3.7.1 USB ports – minimum 6 nos., out of which minimum 2 should be USB 3.0 or better.</p> <p>3.7.2 Display Port – Two Nos. Apart from connecting the computer to display monitors, provision should be provided to simultaneously connect the computer to standard Projectors available in the market.</p>	
3.8	Pointing Device	USB Optical Scroll mouse.	
3.9	Keyboard	Full sized keyboard with integral numeric keypad.	
3.10	Networking	<p>3.10.1 1Gbps Ethernet port. LAN speed should be sufficiently large enough to support the high data rate described in 2.1.14.</p> <p>3.10.2 One Additional 1Gbps Ethernet port to connect computer to LPSC (B) network.</p> <p>3.10.3 One 8/12 port 1Gbps unmanaged network switch should be mounted in the rack provided with the quoted system</p> <p>3.10.4 The network port shall be RJ45connector</p>	
3.11	Additional Display Port	One number, apart from connecting the computer to display monitors, shall have provision to simultaneously connect the computer to standard high-resolution external LED display or external projector.	
3.12	Graphics	<p>3.12.1 Integrated dual graphics supporting FHD resolution. Video interface: Display Port, HDMI</p> <p>3.12.2 Graphics card shall support simultaneously three displays in the following configuration</p> <p>3.12.3 2 monitors in Dual Mode configuration.</p> <p>3.12.4 1 for external projector or high-resolution external LED display with HDMI interfaces to display the content of one of the dual monitors.</p>	

Sl. No.	Vibration Data Acquisition System		Compliance
3.13	Licensing and recovery of OS	The OS to be supplied i.e. Windows should be licensed with license key. OS Recovery and Driver DVD to be supplied.	
3.14	Removable Hard disk	2 nos. of 2TB removable HDD with USB interface for data portability.	
3.15	Printer and scanner	<p>3.15.1 1 No. of Color Laser jet Printer with scan function, built-in USB & network port, with automatic duplex (double side) printing capability, Paper size: A4, printing speed of minimum of 30 PPM and resolution of minimum of 600 dpi.</p> <p>3.15.2 The printers shall be of latest model, supplied with Indian warranty and shall be locally serviceable.</p>	
4.	Software - Basic System Software Features		
4.1	The software should cater for acquisition, throughput recording, analysis and report generation of vibration data for satellite propulsion subsystem. Software license provided for all modules should be on perpetual basis.		
4.2	Software should support on-line acquisition and throughput of time domain data of all the channels with the maximum sampling rate during all modes of test data acquisition using built-in throughput disk.		
4.3	Software should support simultaneous on-line acquisition, analysis, display and storage of both time and frequency domain data during sine, random and shock tests. It should also support post processing of raw time domain data both in frequency domain and in time domain.		
4.4	The software should be able to display entire time domain data of selected Channels in a single plot during post processing.		
4.5	Provision should exist for selecting the channels randomly for acquisition.		
4.6	<p>Following pre-acquisition parameters should be user selectable in spreadsheet style setup in all the software packages.</p> <p>4.6.1 Setting-up of measurement channels before the start of acquisition process.</p> <p>4.6.2 Manual Input of calibration factor, channel sensitivity.</p> <p>4.6.3 Provision should exist for tagging each of the channels with user defined channel names and accelerometer directions such as +x, -x, +y, -y, +z, -z.</p> <p>4.6.4 Amplitude conversion factor to convert incoming signal voltage to Engineering Unit.</p>		

Sl. No.	Vibration Data Acquisition System	Compliance
4.7	<p>Following features should be available with respect to pre-acquisition setup.</p> <p>4.7.1 Storing of channel configuration data in file for future recall.</p> <p>4.7.2 Printing of channel parameters.</p> <p>4.7.3 Storing of the setup parameters along with the data after acquisition.</p> <p>4.7.4 Importing of setup parameters from MS Excel file / ASCII file.</p>	
4.8	<p>Method of Data Capture (Trigger)</p> <p>4.8.1 Through manual command using keyboard/mouse.</p> <p>4.8.2 Transient triggering by waiting for a transient (impulse) to occur before acquiring the data.</p> <p>4.8.3 Positive, Negative and Bi-polar trigger signal.</p>	
4.9	Time duration of acquisition for throughput at maximum sampling rate on all channels – Minimum of 600 seconds.	
4.10	Provision should exist for time domain data display of all channels for the purpose of verification prior to acquisition	
4.11	Following display features should be provided in all the software packages.	
4.12	Data of a single channel should be displayable with option for peak picking.	
4.13	<p>Provision for data display in a single window for comparison either with over-plotting, or with tiled display of</p> <p>4.13.1 Multiple channels of single test (i.e. within the same set of data)</p> <p>4.13.2 Multiple channels data from multiple tests</p> <p>Data of multiple channels of single and multiple tests should be displayable in multiple windows.</p>	
4.14	Waterfall display of the selected channel.	
4.15	Zooming of a selected band in the graph should be possible.	
4.16	Data tracking cursor for identifying graph values should be provided. It should be possible to mark multiple peaks using single cursor.	
4.17	Automatic peak picking in the selected range of frequency and amplitude. Provision for manual peak picking to add additional peaks along with automatically picked peaks.	
4.18	Manual & Automatic setting of the range for X and Y-axes.	
4.19	Option to set Linear/logarithmic scale for X and Y-axes.	
4.20	Option to enable/disable grid lines.	

Sl. No.	Vibration Data Acquisition System	Compliance
4.21	Hard copy printing option for all the above display plots. Software should be able to support the general LaserJet printers and in particular the Color LaserJet printer supplied along with the system.	
4.22	Batch printing of selected channels with automatic peak picking in selected range of frequency and amplitude	
4.23	4.23.1 Facility should be present to save the display plots in PDF format as well as 4.23.2 Microsoft word or equivalent format for report generation purpose. 4.23.3 It should be possible to export all plots of a test at once to MS word or equivalent with optional peak picking for each of the plots.	
4.24	Option to list identified points on the graph along with the graph should be available. This feature should be supported in hard copy generation also.	
4.25	The software should support export of time data in binary and processed data files in ASCII and binary formats of the following format definitions 4.25.1 Universal File Format – data set 58/58B and other data sets. 4.25.2 Spread sheet format (Microsoft Excel or equivalent). 4.25.3 ASCII format. 4.25.4 MATLAB Binary and MATLAB ASCII. Importing of time and processed data in Universal File Format – data set 58/58B should be possible.	
4.26	Provision for initial diagnostics of the instrumentation front end in case of any hardware problems.	
4.27	Provision for on-site Instrumentation Front-end Calibration should be provided with Calibration Software and associated accessories for field calibration as per specification 2.16.	
4.28	Provision to view the time and processed data in any other computer connected to LAN of LPSC-Bengaluru	
5.	Random Data Analysis	
5.1	The Software module should support data acquisition, analysis and storage of the responses monitored at various locations on the test specimen during random vibration test.	
5.2	Real time FFT operation to be performed and displayed to obtain frequency domain transformation of the time domain signal.	
5.3	Following pre-acquisition parameters should be user selectable. These are in addition to the parameters described above in section 4.1 (Basic System Software Features).	

Sl. No.	Vibration Data Acquisition System	Compliance
5.4	Frequency Range selectable from 0 – 10Hz to 0 – 40KHz in discrete steps.	
5.5	Sampling rate selectable from 25 to 100KHz in discrete steps.	
5.6	Number of spectral lines – 200 to 16384.	
5.7	Number of averages – 1 to 1000.	
5.8	Type of Averaging. 5.8.1 Linear 5.8.2 Peak Hold 5.8.3 Exponential averaging 5.8.4 No Averaging	
5.9	FFT overlap definable in percentage from 0% to 90%	
5.10	Windowing function 5.10.1 Hanning 5.10.2 Keiser Bessel 5.10.3 Rectangular 5.10.4 Exponential	
5.11	Off-line analysis of the stored time domain data should be possible. In off-line analysis, it should be possible to perform analysis with frequency range that is lower than the one defined during acquisition.	
5.12	The following analysis features should be possible in both on-line and offline. 5.12.1 Power Spectral Density function of a given channel 5.12.2 Cross spectral density function between any two channels 5.12.3 Auto Correlation of a given channel and cross correlation between any two channels 5.12.4 Coherence function (defining the linear dependency between two signals over a given frequency range) between any two channels 5.12.5 Computation of RMS values for selected band of frequency 5.12.6 Octave analysis with option to select order of analysis from 1/1 Octave to 1/24 octaves or better. 5.12.7 Phase spectrum between any two channels 5.12.8 Real and imaginary plot (with respect to frequency) of a spectral density function for any channel 5.12.9 Transmissibility (FRF) – amplitude and phase transfer function of a channel with respect to another channel	

Sl. No.	Vibration Data Acquisition System	Compliance
	<p>5.12.10 Along with the display of the plot of the selected channel, statistical parameters such as rms, maximum and minimum amplitude with frequency, etc., should be displayed</p> <p>The following analysis features should be supported in off-line analysis mode.</p> <p>5.12.11 Integration and Differentiation of a given channel</p>	
5.13	Printing options must be provided as described above in section 4.1 (Basic System Software Features).	
6.	Sine Data Acquisition and Analysis	
6.1	The system should support swept sine data analysis. The Software module should support data acquisition and analysis of the responses monitored at various locations on the test specimen during swept sine test. Simultaneous on-line acquisition, recording and analysis (as per section 4.3.2 below) of the time-domain data in real time should be possible.	
6.2	The acquisition process should adopt frequency estimation technique where, instantaneous frequency information is obtained by counting the number of zero crossings in a frequency reference signal and computing the frequency value or equivalent. Amplitude of all the data channels should be obtained by estimating the instantaneous amplitude value of the corresponding channels.	
6.3	Both filtered response (the response at the fundamental excitation frequency only, with the contributions of other frequencies removed) and overall or unfiltered response (response over the entire selected frequency range) should be computed and stored separately along with the phase information. It is preferred to have simultaneous computation of both filtered and unfiltered responses.	
6.4	The phase response of a given channel should be computed with respect to the filtered response of the channel.	
6.5	<p>The bandwidth selected for computation of the filtered response (amplitude) can be either,</p> <p>6.5.1 Proportional Bandwidth</p> <p>6.5.2 Fixed Bandwidth.</p>	
6.6	Provision should exist to concatenate minimum of THREE runs of a single swept sine test for the purpose of display and plotting of both filtered and unfiltered data in a single plot	
6.7	Off-line analysis of the stored time domain data should be possible. In off-line analysis, it should be possible to perform analysis with frequency range that is lower than the one defined during acquisition by applying user definable low pass filter.	

Sl. No.	Vibration Data Acquisition System	Compliance
6.8	Following pre-acquisition parameters should be user selectable. These are in addition to the parameters described above in section 4.1 (Basic System Software Features).	
6.9	Frequency Range from 5Hz to 20KHz with corresponding sampling rate from 12.5Hz to 100KHz	
6.10	Direction of sweeping. 6.10.1 Up – where the test starts from the given low frequency limit to the set maximum frequency. 6.10.2 Down – where the test starts from the given maximum frequency limit to the set minimum frequency. 6.10.3 Free run – where the test can sweep in either direction.	
6.11	Display and analysis features include: <ul style="list-style-type: none"> • Response spectrum – Amplitude of the response channel versus frequency with filtered response (the response at the fundamental excitation frequency only, with the contributions of other frequencies removed) and overall response (Broadband RMS) options. • Frequency Response Function (FRF – Transmissibility) – both with overall and filtered response options. Option to display the phase with FRF should exist. 	
6.12	Printing options must be provided as described above in section 4.1 (Basic System Software Features).	
7.	Transient Data Acquisition and Analysis	
7.1	The system should support acquisition and processing of transient data as well as to process the data stored in disc, both in time and frequency domains.	
7.2	Following pre-acquisition parameters should be user selectable apart from those described above in section 4.1 (Basic System Software Features). 7.2.1 Sampling rate up to the maximum limit of 100 KHz. 7.2.2 Time duration of Acquisition	
7.3	It should be possible to carry out the following operations on the time domain signal before computing SRS. 7.3.1 Filtering of the signal with low pass / band pass filters with user defined cut-off frequencies. 7.3.2 DC offset removal (wavelet-based DC Offset removal technique may also be provided as an option) 7.3.3 Trend removal.	
7.4	Shock Response Spectrum (SRS) Analysis with following parameters user selectable. 7.4.1 Damping – 1 to 99%.	

Sl. No.	Vibration Data Acquisition System	Compliance
	7.4.2 Frequency Range – up to 20 KHz. 7.4.3 Octave analysis Definition 7.4.4 1/1 Octave 7.4.5 1/3rd Octave 7.4.6 1/6th Octave 7.4.7 1/12th Octave 7.4.8 1/24th Octave	
7.5	Display of following SRS plots with option of displaying them in a single window (either overlapping of the SRS plots or displaying one next to another) along with time domain signal. Primary, Residual, Positive, Negative and Maximax SRS.	
7.6	Overlap user defined reference and tolerance bands along with SRS plot of acquired shock data.	
7.7	Off-line analysis of the stored time domain data should be possible.	
7.8	Printing options must be provided as described above in section 4.1 (Basic System Software Features).	
8.	Mathematical Processing	
8.1	Following operations should be possible on acquired raw time domain data and processed data.	
8.2	Data-Data arithmetic (+, -, * and /) between any two selected channels.	
8.3	Data-Constant arithmetic (+,-,* and /) for a selected channel with data in real/complex/magnitude-phase format.	
8.4	Integration and differentiation of a given channel data.	
8.5	Signal manipulation such as Append signal to Dataset, copy whole signal, Extract named elements, Repair signal, replace signal, include signals to dataset, Copy section of signal, etc.	
8.6	Filtering operations – low pass, high pass, band pass and band stop – with Bessel and Butterworth filter characteristics.	
8.7	Ability to add user defined routines using built-in programming environment or routines developed using MATLAB/C/C++/Java programming environments. It should be possible to invoke these user defined routines within the acquisition and analysis packages defined above.	
8.8	It should be possible to re-process time domain data that is modified using the above mathematical tools in random/sine/transient analysis modules.	

Sl. No.	Vibration Data Acquisition System		Compliance
9.	Electrical Power Supply & Operating Environment: The supplied hardware should be able to run with the following electrical supply and environmental conditions. The vendor should supply the system with India compatible power-cords.		
9.1	Electrical Supply		
9.2	Voltage	220 Volts AC +5% and -10%	
9.3	Frequency	50 z ±1.5%	
9.4	Operating Environment		
9.5	Operating and storage temperature	15°C to 35°C	
9.6	Relative Humidity	20% to 80%	

Signal Conditioner System

Sl. No	Parameters	Specifications	Compliance
1.	Make and Model	Oasis from M/s MEGGIT, USA (or) 2964 A from M/s Bruel & Kjeaar, Denmark	
	Inputs	IEPE / Voltage Input	
	No of channels	48	
2.	Connectors and interfaces		
2.1	Input connectors	BNC	
2.2	Output connectors	BNC (For connectors other than BNC, suitable cable of 15 m length with BNC terminations to be supplied or 19" rack mountable breakout box with BNC connectors for each channel output to be supplied.)	

Sl. No	Parameters	Specifications	Compliance
2.3	Digital control interface	2.3.1.1 Front panel settable / Settings from PC through RS-232/USB/LAN. 2.3.1.2 Multiple units may be settable through master slave configuration. In such case the cable length should be around 15 m from PC to Master unit (in case of RS232/LAN) and the cable length should be around 1m between master unit to slave unit.	
3.	PC and Application software:		
3.1	PC and operating system	3.1.1.1 One computer to control all signal conditioning units. 3.1.1.2 The Computer should have a reliable Operating system supporting the interface software for the signal conditioner unit.	
3.2	Processor	Intel Core I7 or better	
3.3	RAM	32 GB, DDR3 or more	
3.4	Hard disk	3.4.1.1 2 TB or better 3.4.1.2 The hard disk should be divided into two logical drives one for OS/application software and another for data.	
3.5	Monitor	One 32" full HD TFT LED monitor.	
3.6	DVD-R/W Drive	24X or better DVD Super Multi double-layer drive with DVD and CD read-write capability.	
3.7	I/O ports	3.7.1.1 USB ports ver. 3.0 minimum of 6no. 3.7.1.2 RS232 interface ports – minimum of 2nos.	
3.8	Pointing Device	USB Optical Scroll mouse.	
3.9	Keyboard	Space saver ergonomic keyboard with 104 keys or better.	
3.10	Networking	1 Gbps Ethernet port. (In case, the signal conditioner system uses Ethernet port to communicate to PC for parameter	

Sl. No	Parameters	Specifications	Compliance
		settings, additional 1Gbps Ethernet port to be provided for connecting to the local intranet.)	
3.11	Application software	The application software should interface the signal conditioner unit to the PC for setting various parameters. The software CD/DVD should be provided for each unit.	
4.	Others		
4.1	Operating Temperature	15°C to 35°C	
	Voltage	90- 230 V AC or suitable power adaptor.	
4.2	Frequency	50 Hz \pm 1.5 %	

Accelerometers

1.	Introduction: Vendor shall supply Accelerometers from any of the blow mentioned Make and Model.		
Sl. No.	Features	Range/value	Compliance
1.1	Type – 1 (Qty. 10 Nos.)		
1.1.1	Sensitivity	100 mV/g	
1.1.2	Make and Model No.	a) ENDEVCO: Model No. 41A16-1032 (or) b) DYTRAN: Model No. 3056D2 (or) c) B&K: Model No. 4533-B-001 (or) d) KISTLER: Model No. 8704B50M1	
1.2	Type – 2 (Qty. 15 Nos.)		
1.2.1	Sensitivity	50 mV/g	
1.2.2	Make and Model No.	a) DYTRAN: Model No. 3056D5 (or) b) B&K: Model No. 4534-B-004	
1.3	Type – 3 (Qty. 20 Nos.)		
1.3.1	Sensitivity	10 mV/g	

1.	Introduction: Vendor shall supply Accelerometers from any of the blow mentioned Make and Model.		
Sl. No.	Features	Range/value	Compliance
1.3.2	Make and Model No.	ADHESIVE BONDING TYPE: a) ENDEVCO Model No. 41A13-1032 or b) PCB: 352C43 c) Dytran: 3225F2 d) PCB: 355B02 e) B&K: 4517C002 STUD TYPE: a) KEISTLER: 8704B500	
1.4	Type –4 Tri-Axial Accelerometer along with cable (Qty. 20 Nos.)		
1.4.1	Sensitivity	10 mV/g	
1.4.2	Make and Model No. (Cable of length 10 m terminated to 10-32 UNF male thread to be supplied)	a) DYTRAN: Model: 3023A b) KISTLER: Model: 873B500BB c) B&K: Model: 4520 d) PCB: Model: 356B21 e) ENDEVCO: Model:65-10-R	

Low Noise Cables for Accelerometers

1.	Introduction: Vendor shall supply Accelerometer Cables from any of the blow mentioned Make and Model.		
Sl. No.	Features	Range/value	Compliance
1.1	Type - 1		
1.1.1	Make and Model No.	a) M098EB060PW from PCB, USA (or) b) C-001-AA-002-2400 from Meggitt-Endevco, USA	
1.1.2	Cable Length	60 meters	
1.1.3	End Connection	10-32UNF male at one end and BNC male connector at the other end with strain relief on both ends.	

1.	Introduction: Vendor shall supply Accelerometer Cables from any of the blow mentioned Make and Model.		
Sl. No.	Features	Range/value	Compliance
1.1.4	Quantity	100 Nos.	
1.2	Type - 2		
1.2.1	Make and Model No.	a) M098EB010EB from PCB, USA (or) b) C-001-AA-001-0394 from Meggitt-Endevco, USA	
1.2.2	Cable Length	10 meters	
1.2.3	End Connection	10-32UNF male with strain relief on both ends	
1.2.4	Quantity	100 Nos.	

Isolation Studs

Sl. No	Description		Compliance
1	Make	MEGGITT	
3	Model No	2986B	
4	Thread Size, Accelerometer side	10-32UNF male	
5	Thread Size, mounting side	10-32UNF male	
6	Quantity	150 Nos.	