

SRQA LPSC
CC RELEASE

CHD.	CHD.
APPD.	APPD.

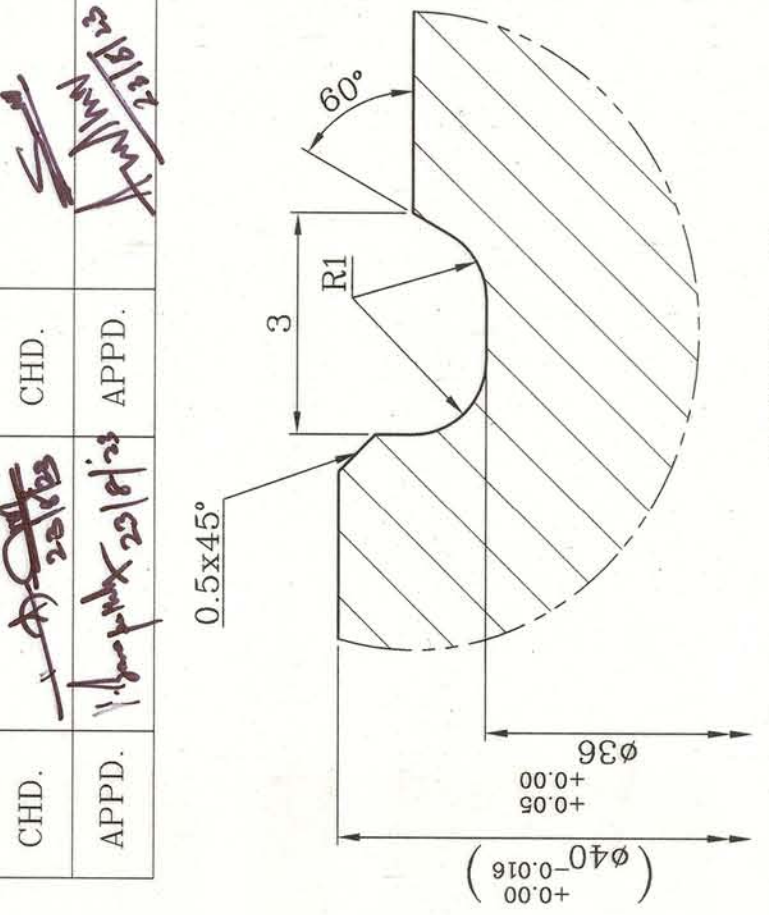

DETAIL - C
SCALE-10:1

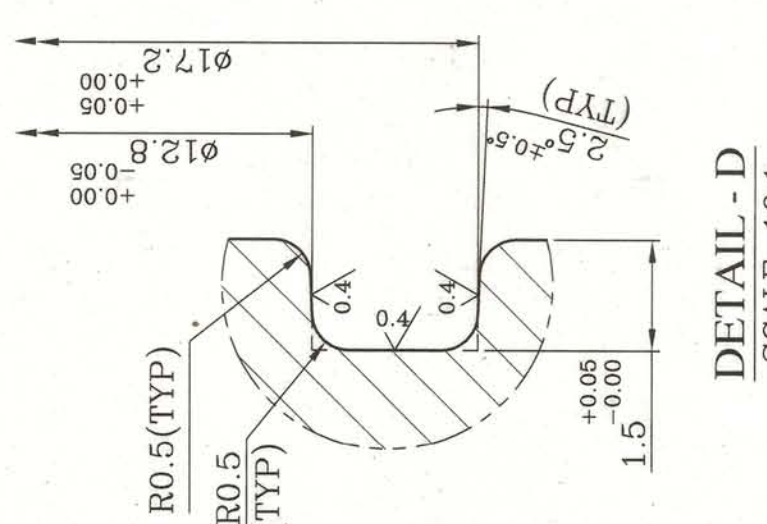

DETAIL - D
SCALE-10:1

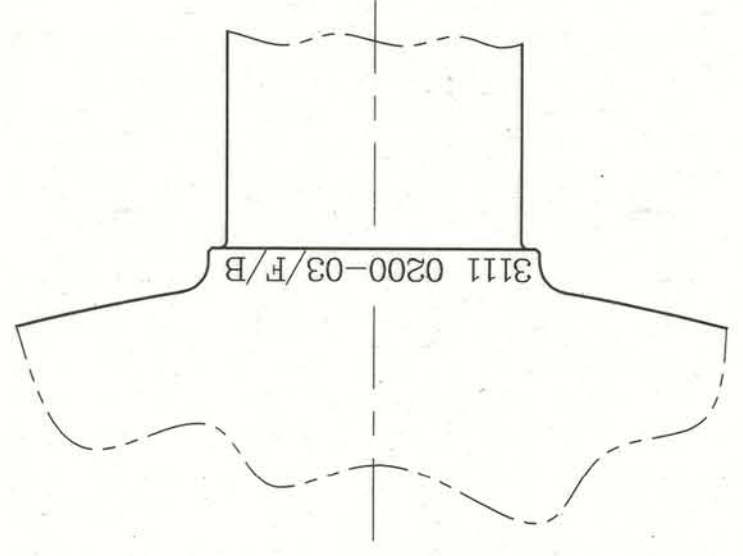

DETAIL - F

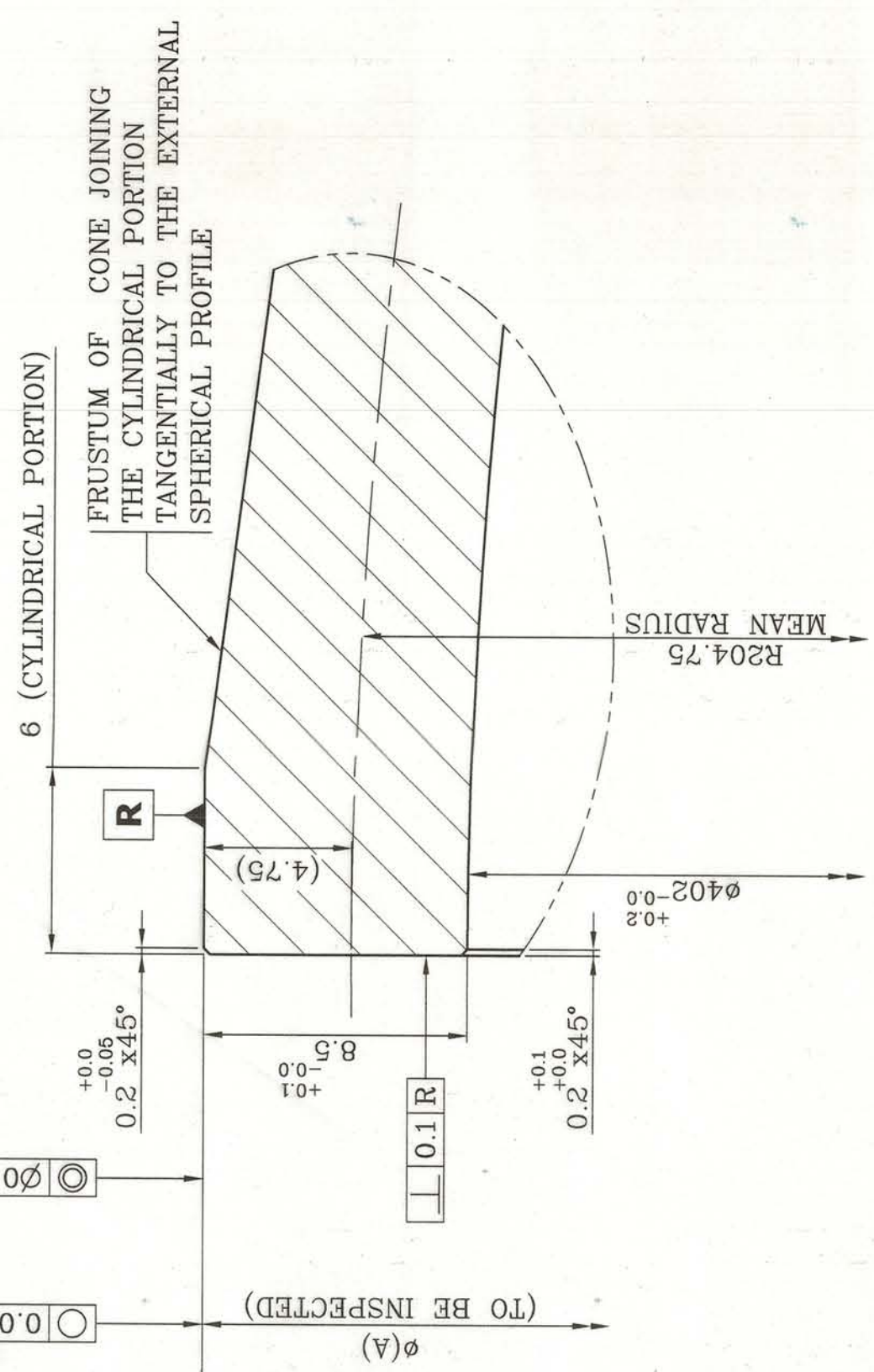
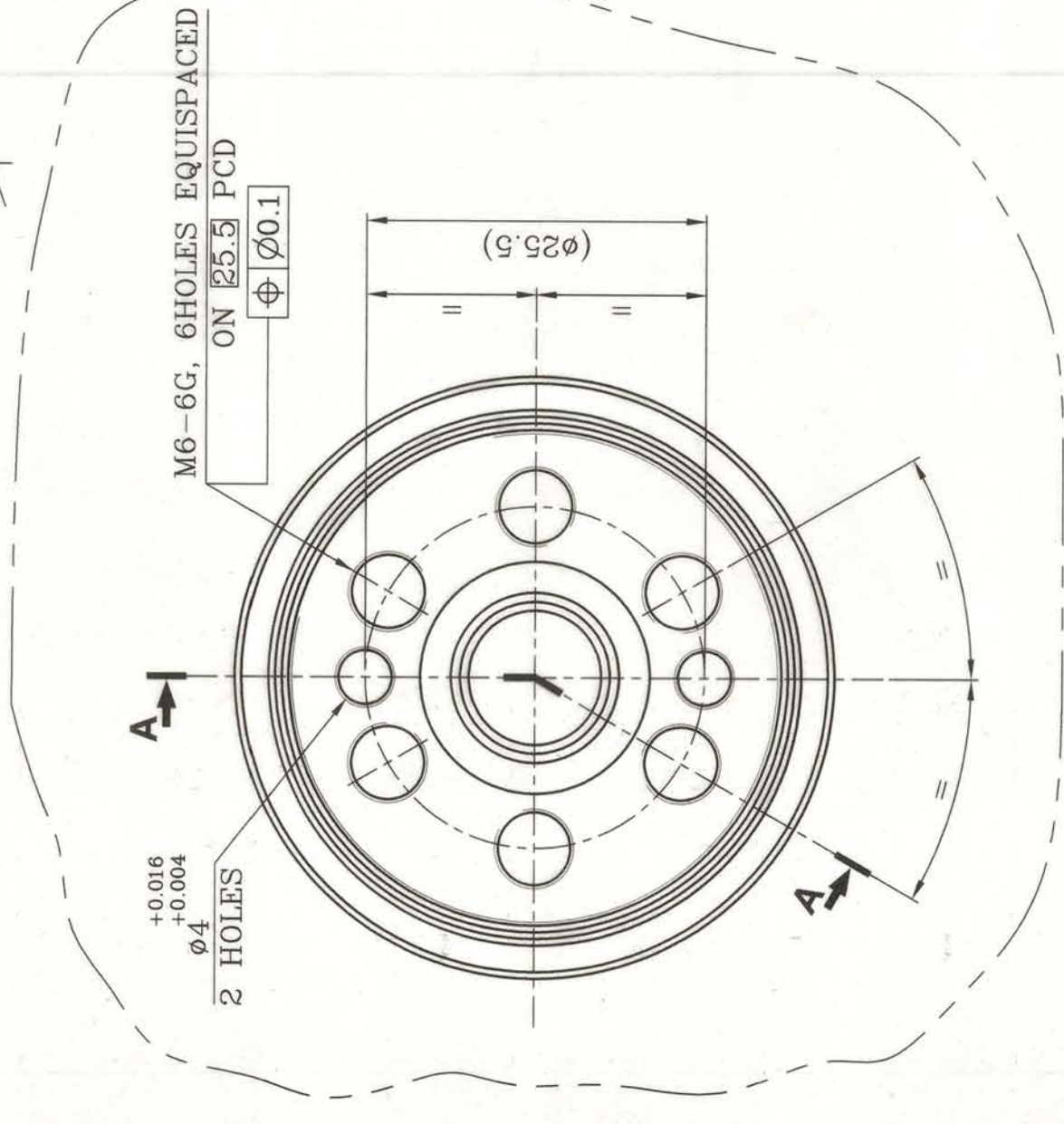
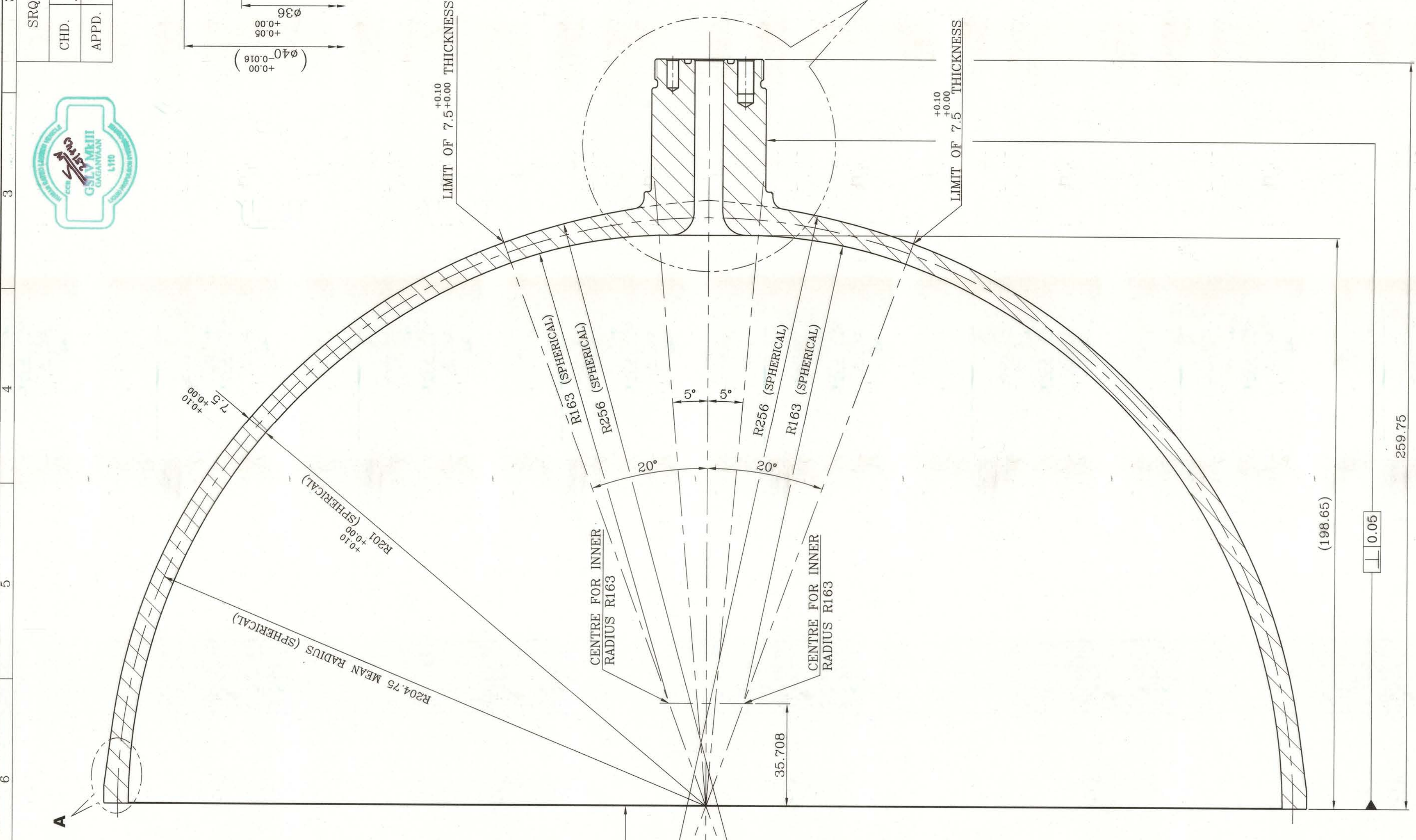

DETAIL - A
SCALE-5:1

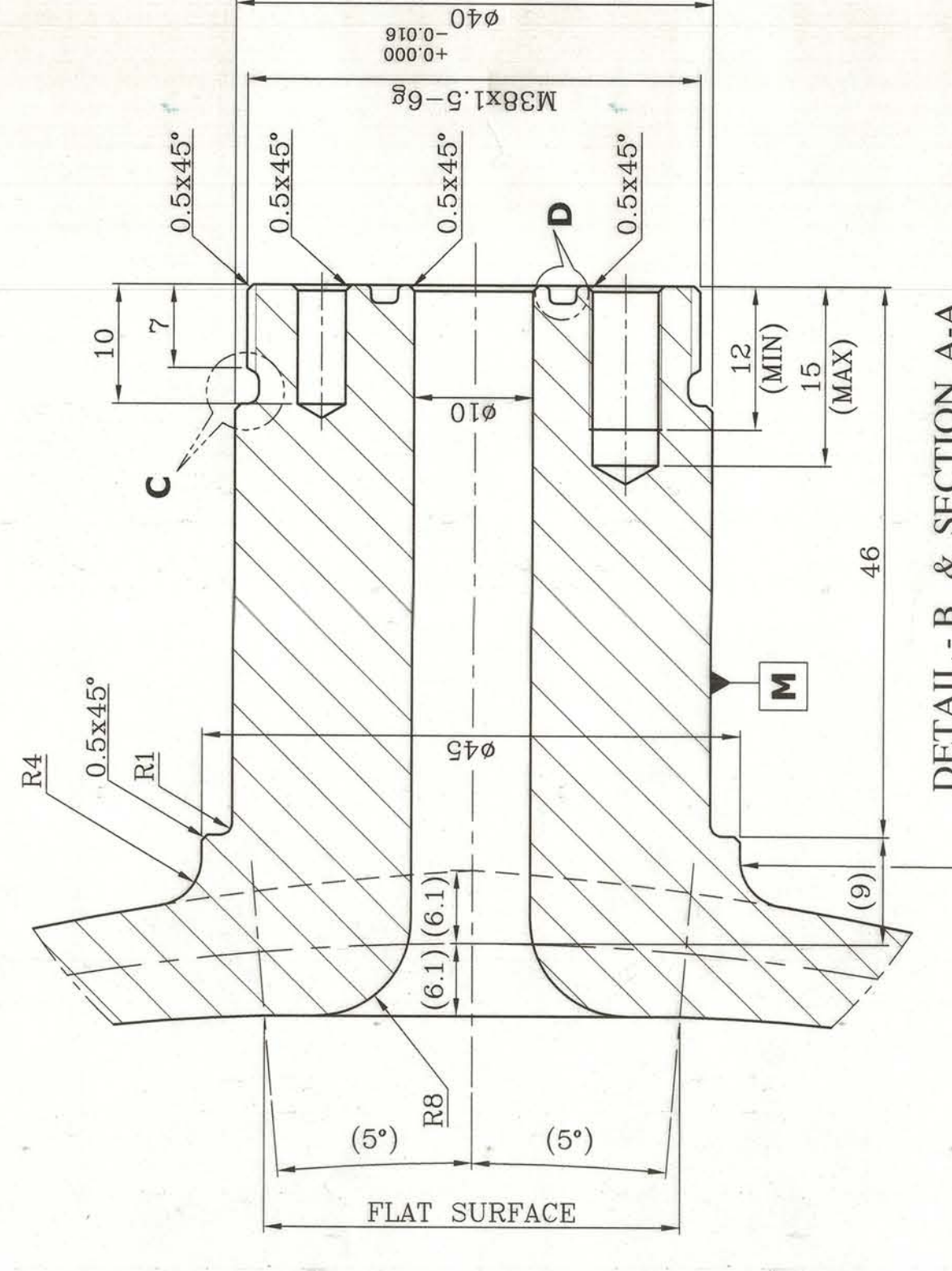

DETAIL - B & SECTION A-A
SCALE-2:1

PART No. MARKING : 3111 0200-03/F (FORGING SL.NO.) / B(BOTTLE SL.NO.) BY ENGRAVING
 HEIGHT OF MARKING : 3mm
 DEPTH OF MARKING : 0.2max
 REFER DETAIL 'F' FOR MARKING DETAILS

PRECAUTIONS FOR MACHINING Ti6Al4V

- AVOID OVER HEATING
- AVOID USE OF CHLORINATED CUTTING FLUID
- USE ONLY IPA FOR CLEANING AND DEGREASING

MACHINING FINISH IN MICRONS		SURFACE FINISH	
V	10-15	1.6	0.4
∇	16-25	3.2	0.8
∇∇	25-50	6.3	1.6
∇∇∇	50-100	12.5	3.2
∇∇∇∇	100-200	25	6.3
∇∇∇∇∇	200-400	50	12.5
∇∇∇∇∇∇	400-800	100	25
∇∇∇∇∇∇∇	800-1600	200	50
∇∇∇∇∇∇∇∇	1600-3200	400	100
∇∇∇∇∇∇∇∇∇	3200-6400	800	200
∇∇∇∇∇∇∇∇∇∇	6400-12800	1600	400
∇∇∇∇∇∇∇∇∇∇∇	12800-25600	3200	800
∇∇∇∇∇∇∇∇∇∇∇∇	25600-51200	6400	1600
∇∇∇∇∇∇∇∇∇∇∇∇∇	51200-102400	12800	3200
∇∇∇∇∇∇∇∇∇∇∇∇∇∇	102400-204800	25600	6400
∇∇∇∇∇∇∇∇∇∇∇∇∇∇∇	204800-409600	51200	12800
∇∇∇∇∇∇∇∇∇∇∇∇∇∇∇∇	409600-819200	102400	25600
∇∇∇∇∇∇∇∇∇∇∇∇∇∇∇∇∇	819200-1638400	204800	51200

MATERIAL Ti6Al4V ANNEALED		SURFACE TREATMENT	
Mechanical Properties		General tolerance AS 2000 MEDIUM GRADE & CLASS 'K'	
General tolerance AS 2000 MEDIUM GRADE & CLASS 'K'		Thread tolerance	
Thread tolerance		Thread chamfer & under cut.	
Radii not specified		Marking Drawing No. BY ENGRAVING	
Chamfers not specified		Quantity 1	
Quantity 1		Mass 9.15 Kg	

TITLE	
HEMISPHERE (MALE)	

REVISION	
INDEX	MODIFICATION ORDER No. & DATE
01	WELDING JOINT
02	(H) END BOSS
03	(I) THICKNESS

PROJECT	
GOVERNMENT OF INDIA INDIAN SPACE RESEARCH ORGANISATION LIQUID PROPULSION SYSTEMS CENTRE VILLIAPURAM TRIVANDRUM-695547	

FORM	
REV. NO.	03
DRG. No.	PU410-3111 0200
SCALE	1:1 & NOTED
SHEET	1 OF 1

NO. OF ASSY.	
1	PU410-3111 0001
TITLE	
NEXT ASSEMBLY	
195/PSA	DI: 30.03.2021
134/PSA	DI: 22.12.2011
24.07.87	(I) WORKING OF Eng No.
	(II) WORKING OF Eng No.
	(III) WORKING OF Eng No.
	(IV) WORKING OF Eng No.